

Net impact implementation application development life-cycle management in banking sector

Noviana Pramitasari, Yova Ruldeviyani, Irvan Ramadhan Zarkasie

Magister of Technology Information, Faculty of Computer Science, Universitas Indonesia, Jakarta, Indonesia

Article Info

Article history:

Received Jan 5, 2023

Revised Jun 9, 2023

Accepted Jun 21, 2023

Keywords:

Application development life-cycle management

DeLone and McLean model

Net impact

Structural equation modeling

ABSTRACT

Digital transformation in the banking sector creates a lot of demand for application development, either new development or application enhancement. Continuous demand for reimagining, revamping, and running applications reliably needs to be supported by collaboration tools. Several big banks in Indonesia use Atlassian products, including Jira, Confluence, Bamboo, Bitbucket, and Crowd, to support strategic company projects. We need to measure the net impact of application development life-cycle management (ADLM) as a collaboration tool. Using the deLone and McLean model, process questionnaire data from banks in Indonesia that use ADLM. Processing data using structural equation modeling (SEM), multiple variables are analyzed statistically to establish, estimate, and test the causation model. The conclusions highlight that system quality strongly affected only User Satisfaction ($p=0.049$ and $\beta=0.39$). Information quality strongly affected use ($p=0.001$ and $\beta=0.84$) and strongly affected user satisfaction ($p=0.169$ and $\beta=0.28$). Service quality strongly affected only use ($p=0.127$ and $\beta=0.31$). Conclusion research verifies the information system's achievement approach described by DeLone and McLean. Importantly, it was discovered that system usability and quality were key indicators of ADLM success. To fulfill their objective, ADLM must be developed in a way that is simple to use, adaptable, and functional.

This is an open access article under the [CC BY-SA](#) license.



Corresponding Author:

Noviana Pramitasari

Magister of Technology Information, Faculty of Computer Science, Universitas Indonesia

Jakarta, 10440, Indonesia

Email: noviana.pramitasari@ui.ac.id

1. INTRODUCTION

A title of article should be the fewest possible words that accurately describe the content of the paper. An extensive management strategy based on the holistic principle is necessary to address the transformation of organizations towards the use of digital technology and the vast usage of data [1]. Interdependence and coordination are significant themes in organizational studies, according to Crowston (2003). The use of information technologies (IT) has become widespread, creating a dynamic environment full of opportunities and difficulties [2]. In enterprises, achieving IT/business alignment is still more crucial [3]–[9], it serves as one of information technology governance's primary objectives [1]. The capacity to establish a management system where the processes are connected and support one another is crucial for creating value. It is established that processes are impacted by IT and vice versa [10]–[13].

The goal of software engineering is to apply the top techniques for creating reliable software systems [14]. The various applications you come across could be in the business, engineering, or even scientific fields. Software systems are now used in a wide range of applications. It is crucial to carefully monitor and analyze the development progress of any software solutions that will last for a long time.

According to the engineering approach, software development must follow a clearly defined, methodical strategy to have a very high possibility of success [15], [16]. The software development life cycle (SDLC), as a well-defined, systematic process is the major advantage of the engineering approach, is a vital technique for the development of software and includes designing a sequence of various activities and phases [14]. They are requirements gathering, designing, programming, testing, and servicing [14], [17]. Additionally, this method is thought to be particularly documentation-heavy; as a result, numerous documents in a standard style and in contractual duties are prepared as a starting point for later use. To keep towards the authorized plan in terms of scope, timetable, and scope, the development team plans for and manages risks throughout the project lifetime [18]–[20]. One of the most common projected life cycles is the waterfall model, which calls for fully predicting and documenting a sound set of requirements at the beginning of a project [14].

Almost all banking activities and products are today dependent on information technology due to the banking sector's very strong relationship with technology (IT) [21], [22]. In the process of developing an IT application system, the company carries out the process in accordance with the SDLC governance procedure document that has been determined, which is in addition to the provisions. The application system development process involves many parties in accordance with the responsibility, accountability, control, and inform (RACI) matrix, starting from the user team, product owner, IT business partner, system analyst, programmer, quality assurance tester, operation, security engineer, infrastructure engineers, and other parties. To support the development of both new and current applications within the organization, as well as the powerful party involved in the projects, businesses need an application development life-cycle management (ADLM).

The companies have implemented the Atlassian product as an ADLM. Atlassian products implemented include Jira, Confluence, Bitbucket, Bamboo, and Crowd [23], [24], which function as project management, documentation tools, source code repository, implementation tools (including CI/CD support) and user management. The implementation of project management is expected to expand the use of ADLM not only in the IT team but also with users and product owners. In addition, to support the number of projects or requirements to support business, including strategic initiatives, the number of which is increasing every year. Atlassian's ADLM is expected to be a solution in the management of the application system development process, starting from project management, source code repositories to implementation in massive software development in the company.

The current research, which is concerned with the banking sector, aims to answer concerns raised both the organizational and scientific areas. Therefore, the purpose of this article is to operationalize the DeLone and McLean (1992, 2003, and 2016) net impacts design in the banking industry, with IT and product owner users using ADLM as collaboration tools to manage project software development. Indeed, it is very important for companies to know how the performance of workers perceives SI impact. ADLM system is considered a key strategic element in value creation and competitiveness for the acceleration and quality of the company's business development with system development and system enhancement application.

In other perspective, aim responds to performance talent, according to Herzberg's concept, hygienic factors, or extrinsic rewards impact job unhappiness while motivators or intrinsic rewards affect job contentment [25]. Achievement, praise for achievement, the task itself, responsibility, and progress or advancement are the motivators (intrinsic). Employer regulation and administration, supervision, human relationships, the workplace culture, income, position, and protection are examples of extrinsic factors that influence workplace hygiene or the prevention of discontent [25].

2. METHODS

The purpose of this subtitle is to clarify the conceptual basis of the research and to explain the main views on implementing and assessing information systems. Various inherent theories in evaluating IT adoption and analyzing numerous underlying methods and concepts are also developed. The following is an explanation of the concepts, models, research instruments, data collection, data processing carried out in this study.

2.1. The concept of net impacts

DeLone and McLean (1992) provided a synthesis of the current studies in the form of a general model unifying the literature based on the heterogeneity of research [26]. They introduced the information system success model (ISSM), which is currently regarded as one of the key models for IS evaluation by the scientific community. However, businesses rarely use it [27]. Instead, they mention guidelines like ITIL, COBIT, or CMMI to guarantee the quality of IS, the monitoring of practices or the level of IS maturity, and even its governance [27]. ISSM, initially made up of five factors, is multidimensional, recognizing that both temporal and causal influences are necessary for IS to succeed as a built process [27]. More specifically, this

model shows that information and system quality influence user happiness and IS use, which in turn effect individual impact. Utilization can influence user pleasure, but vice versa is also true. Organizational effects result from individual effects [27]. DeLone and McLean defined the individual and organizational levels of effect in their 1992 model using a taxonomic method. These authors proposed an updated version of their model to address several objections [28], such to the absence of empirical studies and the non-operationalization of variables. Additionally, they addressed concerns of the model's process- and/or causal nature as well as the variables' selection and relationships with one another (dependent or independent variables). Consequently, their new model has three key adjustments [24].

More recently, DeLone and McLean took three stock of current developments in IS evaluation in their 2016 book and recalled the origins of their multidimensional approach, as displayed in Figure 1 [29]. These two writers suggest two significant modifications to the 2003 model [26]. First, net benefits is changed to net impacts for the variable. The researchers use the beneficial element of the idea of profit to support this shift. An IS, however, can provide outcomes that have an impact on user satisfaction as well as use intention, either positively or negatively. Second, they add fresh feedback to their model [27]. This assumes that users will have identified issues and opportunities for improvement because of their experience with IS. As a result, there are maintenance needs that affect the quality of the IS, data, and capabilities [27].

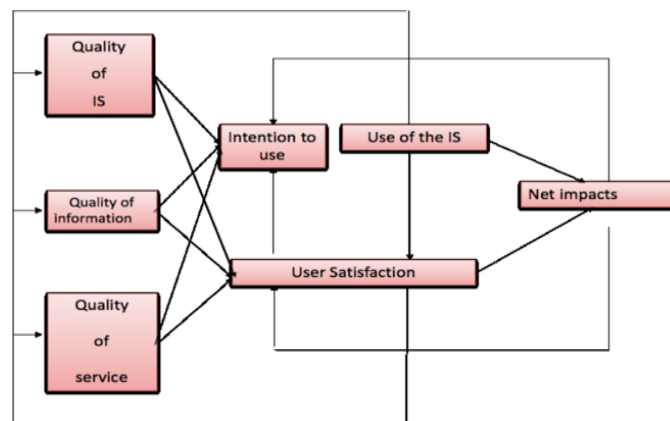

Figure 1. Requires effective DeLone and McLean's (modified) (2016) [26]

2.2. Net impact

The modified DeLone and McLean model serves as the foundation this research [30]. The model provides six interrelated quality factors (information, system, and service quality) that may impact future usage or intention to use as well as user satisfaction. These constructs are used to quantify the success of information systems. It is additionally indicated that even some benefits identified as net benefit would be obtained as result of use and/or user satisfaction. Therefore, user happiness and system usage could be impacted by these net benefits. Following are more explanations of the conceptualization of the constructs in this research.

- System quality: Done to assess desired properties of an information system. In this situation quantified by numerous IS research utilizing factors like perceived usability, adaptability, speed of response, and features of the system [31]. The efficiency of use connected with ADLM, but to assess system quality, this study looked at functionality and flexibility as well.
- Information quality: This concern with content problems and information system content characteristics. The result of an information system was already assessed in terms of its consistency, responsiveness, correctness, and authenticity [31]. The accuracy, usability, and timeliness of the information produced by the ADLM in use were operationalized in this study.
- Service quality: The developer of the information system's level of support is used to evaluate this. Research has evaluated this by using the service quality criteria, such as the availability of user training and the software supports council's response [31]. In this study, network infrastructure, system dependability, and technical assistance for ADLM customers were all examined as indicators of service quality.
- Intention to use/use: This focuses on evaluating the way that an information system is used. This has been measured in several studies by looking at actual usage or, occasionally, usage frequency [31]. Depending on the information system, the intention to use is also referred to as a replacement indicator

to use in other situations [30]. ADLM, this research evaluated use from perspective of perceptions because previous research has shown that evaluating real use for this context could be meaningless. In addition, expect and need their staff to utilize the system [32].

- User satisfaction: Some of the most crucial indicators of an organization's achievement is usually evaluated by assessing entire user satisfaction [30], [31]. By measuring total user satisfaction with ADLM, it was evaluated in the study.
- Net benefits: The scope of an IS's effects, either positively or negatively, to the success of key parties, is one of the most crucial indicators of an IS's success. It has occasionally been quantified by evaluating the influence on either the individual or the organization [31]. However, because key users of ADLM were polled for this study, net benefits were assessed as perceived net benefits.

The model that drives this research is shown in Figure 2. As a result, the following theories were proposed and examined:

- H1: Use will gain from system quality.
- H2: User satisfaction will gain from system quality.
- H3: Use will gain from Information quality.
- H4: User satisfaction will gain from information quality.
- H5: Use gain from service quality.
- H6: User satisfaction will gain from service quality.
- H7: User satisfaction will gain from use.
- H8: Perceived net benefit will gain from use.
- H9: Perceived net benefit will gain from user satisfaction.

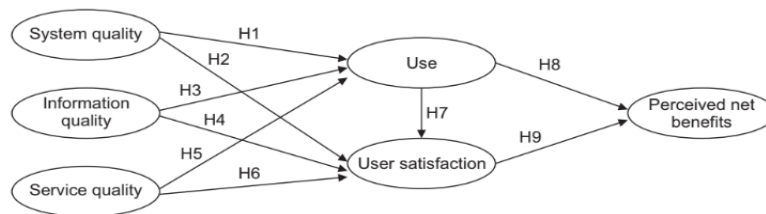

Figure 2. Research model using DeLone and McLean [28]

2.3. Approaches to measuring net impacts

In previous research, the measurement of net impact has been carried out by measuring instrument dimensions. Four previous researches are listed, along with an explanation of each measuring instrument dimensions. A review of the research on IS's net impacts is conducted in Table 2.

2.4. Structural equation modeling

A type of linearity modeling tool that uses statistical data is called a structural equation model (SEM), and it is particularly useful for problems involving unobservable variables [33] It is a method of multivariate statistical analysis that is used to build, estimate, and test causality models. A hypothesis that serves as the basis for SEM must be tested to validate the validity of the hypothesis. These are the test indexes and relative criteria [34]–[36].

Table 2. A review of the research on IS's net impacts is conducted

No	Evaluation of net iImpacts	Authors and year	Measuring instrument dimensions
1	Evaluation of the organizational impacts of IS projects	Mirani and Lenderer (1998)	Strategic benefits Informational benefits transactional benefit
2	Perceived impact of information technology on the work of end users.	Torkzadeh and Doll (1999)	customer satisfaction task productivity management control task innovation
3	Balanced Scorecard model applied to IS (untested model)	Martinsons et al. (1999)	business value perspective user orientation perspective internal process perspective future readiness perspective
4	Evaluating the performance of IS through a functional BSC	Chang and King (2005)	System performance information effectiveness service performance

2.5. Data collection

Two methods were used to collect the data for this research. The first method is interviews with project owners, IT project leaders, and end users who were involved in the early implementation of ADLM. The second data collection method is through a questionnaire with the respondents as direct users of the ADLM. The DeLone and McLean concept [28], which uses a scale ranging from one for absolutely disagree to five for absolutely agree, instructs respondents to select the most appropriate answer from a set of 24 statements that are related to questionnaire characteristics.

2.6. Interview net impact using DeLone and McLean model

After identifying the concept of net impact, we conducted an interview to validate the relevant factors in the company's impact implementation of ADLM. We interviewed 3 team leaders, they are project owners, IT project leaders, and end users who were involved in the early implementation of ADLM. From the interviews, we identified there are 5 variables for validated DeLone and McLean model related with implementation of ADLM, the factors are intention to use/use, system quality, and user satisfaction, in quality domains are information quality and service quality [37].

2.7. Research instrument questionnaires

The previous research, the list of questions has been defined and then adapted to the application that will be researched this time. Question list in Table 1. We distributed questionnaires to several banks in Indonesia that use ADLM, 2 *BUMN* banks and 2 public banks have filled out the questionnaire, which consists of several roles including product owner/user, programmer, system analyst, business analyst, and tester. Consists of several levels of positions ranging from officer, assistant manager, manager, SN manager, AVP, VP, and EVP. These users consist of work units at head office bank, both IT and users or product owners. The questions given in the questionnaire are 24 questions based on Table 1 question list of DeLone and McLean [37] plus one question in the form of a description in Appendix. One additional question in the description is about criticism and suggestions for the ADLM system. The hope of this additional question is to strengthen the value that will be obtained from ADLM.

Table 1. Question list questionnaire

Variable	No	Item
<i>System quality</i>	1	I find the ADLM easy to use
	2	I find it easy to get the ADLM do what I want
	3	The ADLM is flexible to interact with
<i>Information quality</i>	4	Learning to operate the ADLM was easy for me
	5	The information generated by the ADLM is correct
	6	The information generated by the ADLM is useful for its purpose
	7	The ADLM generates information in a timely manner
	8	I trust the information output of the ADLM
<i>Service quality</i>	9	There is adequate technical support from the system's provider
	10	The overall infrastructure in place is adequate to support the ADLM
	11	The ADLM can be relied on to provide information as when needed
	12	The output of the ADLM is complete for work processes
<i>Use</i>	13	Using the ADLM enables me accomplish tasks more quickly
	14	Using the ADLM has improved my job performance
	15	Using the ADLM has made my job easier
	16	I find the ADLM useful in my job
<i>User satisfaction</i>	17	I am satisfied with the functions of the ADLM
	18	The ADLM has eased work processes
	19	I am generally satisfied using the ADLM
<i>Perceived net benefits</i>	20	The ADLM will help overcome the limitations of the paper-based system
	21	Using the ADLM will cause an improvement in development process
	22	The ADLM facilitates easy access to project information
	23	The ADLM will enhance communication among workers
	24	ADLM use will cause improved decision making

2.8. Data processing

The strength of connections between the model's constructs was investigated using the SEM technique [37]. With the AMOS software ver. 26.0, this was accomplished (IBM, Armonk, NY, USA). To evaluate the model's accuracy, an initial validating factor analysis was performed out. The model's psychometric qualities were then assessed according to internal consistency and composite reliability [37]. The model's pathways coefficients were then looked at Figure 3.

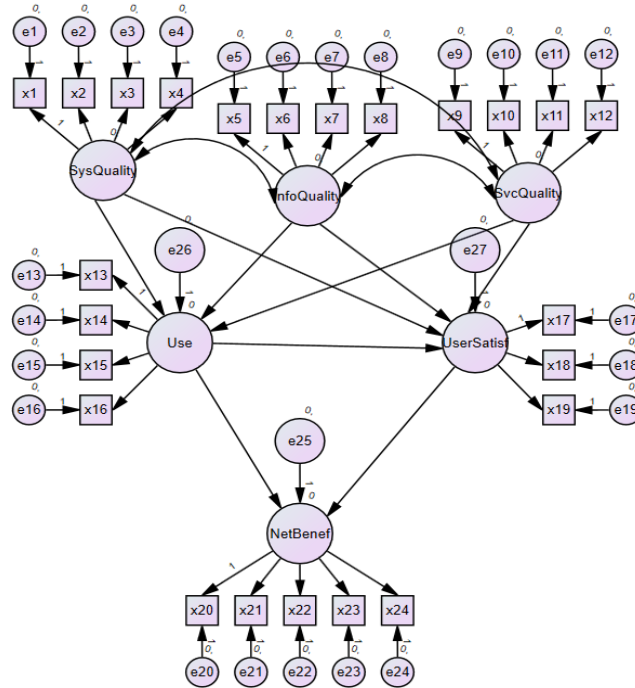

Figure 3. Representation of SEM that was developed using AMOS

3. RESULTS AND DISCUSSION

The following is an explanation of the results and discussion. In this study which includes interview reports and questionnaire reports conducted by researchers. Subsection 3.1 to 3.3 are specifics of the questionnaire and interview results.

3.1. Interview report

Interviews were conducted to obtain reliable information from sources who have a track record and are closely related to the initial process of implementing the ADLM system. The interview's goal is to determine general impact from the implementation of ADLM and validate the relevant factors in the company's impact. In this case, 3 sources were collected with the criteria as key informants and main informants as conveyed by Rahimi *et al.* [11] that the sources were directly involved and knew and had a lot of important information needed in research.

First interviewee is an important figure in the initiation and implementation of ADLM, namely as the project owner who is one of the policy makers for the use of the ADLM system. In 2018 discussions began with the IT work unit and several other work units to implement the ITSM system. Second interviewee is the IT project leader, and third interviewee is the user leader who during the implementation period of the ADLM system was closely related to the development process according to the SDLC.

In this interview, first interviewee who was at the time in the IT strategic and governance division conveyed the background on the selection of the ADLM system and implementation companion vendors, as well as who were the figures involved from planning to system implementation and their interrelationships. With parties related to the SDLC outside the IT Strategic and governance division such as the application management and operation division, IT infrastructure division, IT security division, and business unit/product owner. It is hoped that with the ADLM system there will be a system that is integrated in the application system development process from the entry requirements to the live implementation process in the production environment. The ADLM system can provide a statistical dashboard of project progress that can be searched based on certain keywords, visualization of performance in project completion, and transparent team productivity. This ADLM dashboard also makes it easier for management, especially for the board of directors (BOD) to directly see the status of strategic projects from a helicopter view and can be drilled down in a detailed view as needed. Over time, first interviewee believes that the ADLM system that he initiated has reached a point of success although there is hope that the ADLM system will be used and be more beneficial for all parties in project management. First interviewee said that the successful implementation of the ADLM system was supported by data that stated the number of applications/projects that had been delivered with

project management using the ADLM reached 89% and will continue to grow in accordance with business needs and the vision of transformation that continues to be socialized by the company.

What was explained by the first interviewee was not immediately refuted by the second interviewee. The second interviewee confirmed that the use of ITSM was indeed quite massive and so far, it has had a positive impact on project management completion. The second interviewee regretted that the involvement of business work units/product owners who have only recently used ADLM for project management resulted in not being optimal in the implementation of ADLM. However, the second interviewee did not deny that the successful implementation of ITSM is inseparable from the absence of other options for IT users or businesses that handle project management using the ADLM. The second interviewee also stated that the relevant parties are currently unable to prioritize the creation of a rival ADLM which is more user friendly and effective and efficient in handling the massive business banking project management. The second interviewee said there are still too many rooms for improvement which should be able to improve performance and performance in project completion.

The same thing was also explained by the third interviewee who at that time served as an IT quality assurance application leader in one of the IT work units. In almost the same answer as the second interviewee, the third interviewee conveyed that the development process has become faster because of the lack of an ADLM system that makes SLA or service level agreement and the third interviewee feel that rollback deployments are rarely carried out because uploads have been made, source code to repository and developed CI/CD pipeline. The third interviewee was satisfied with the implementation of ADLM.

From the results of interviews with 3 interviewees, we concluded that the variables for DeLone and McLean model that research of Adebowale I. Ojo, PhD with his paper validation of the DeLone and McLean information systems success model [37] is validated and can be implemented to measure the net impact of ADLM. Because it is in accordance with the variables, question items can be used in the questionnaire data collection stage.

3.2. Questionnaire result

After the questionnaire was distributed, we had 52 respondents participate in this research. The distribution of respondents from the questionnaire consists of several levels of positions and roles, including Officer, Asst. Manager, Manager, Sn Manager, AVP, VP, and EVP. Each of which has a different working time in Figures 4 and 5.

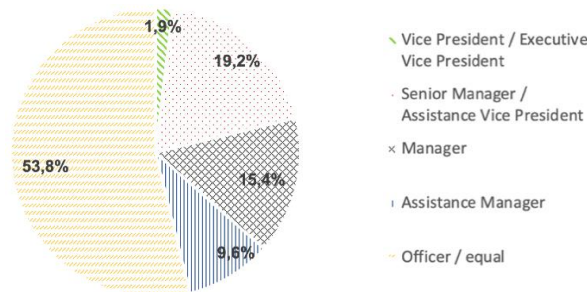

Figure 4. The composition of respondents by position levels

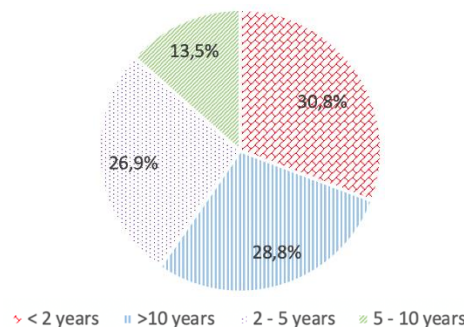

Figure 5. The responders' breakdown according to working years

3.3. Processed output data

From the questionnaire data obtained, it is then processed to the next stage. Processed output data consists of several concerns that become the focus of analysis, including model fit, validity and reliability, test of hypothesis. It is explained in detail as follows.

3.3.1. Model fit

The model's goodness of fit was assessed using this output in Table 3 demonstrates that its research instrument reasonably corresponds to the given data [37]. Because the confirmatory factor values are greater than the levels of recommended acceptability [34], [35]. Consists of data fit indices, suggested value, and achieved value.

Table 3. Model fit measurements

Fit indices	Suggested value	Achieved value
Chi-square ratio (X^2/df)	≤ 3.00	1.69
Goodness-of-fit index (GFI)	≥ 0.90	0.64
Adjusted goodness-of-fit index (AGFI)	≥ 0.80	0.55
Normalized fit index (NFI)	≥ 0.90	0.61
Comparative fit index (CFI)	≥ 0.90	0.79
Root mean square residual (RMSR)	≤ 0.10	0.04
Root mean square error of approximation (RMSEA)	≤ 0.08	0.12

3.3.2. Validity and reliability

Examined were the model's internal consistency, construct accuracy, and individual item stability [37]. A common weight more than 0.7 was regarded sufficient for the individual item reliability [33]. All the items had common weight more than 0.7, according to the findings in Table 4 [37]. Calculating the average variance extracted (AVE) allowed for the evaluation of composite reliability [37], and as a measure of internal consistency, composite reliability (CR) was used to assess construct consistency. Nunnally and Bernstein advise that the CR and AVE should be above 0.7 and 0.5 [36]. The outcomes displayed in Table 4 demonstrate also that model is trustworthy and has respectable composite reliability.

Table 4. Result CR and AVE

Factor	Question number	SD	CR	AVE
System quality	1	0.53	0.73	0.41
	2	0.66		
	3	0.68		
	4	0.70		
Information quality	5	0.57	0.73	0.41
	6	0.72		
	7	0.61		
	8	0.66		
Service quality	9	0.80	0.82	0.54
	10	0.71		
	11	0.59		
	12	0.83		
Use	13	0.66	0.77	0.46
	14	0.70		
	15	0.74		
	16	0.64		
User satisfaction	17	0.65	0.74	0.48
	18	0.70		
	19	0.75		
Perceived net benefits	20	0.72	0.80	0.44
	21	0.59		
	22	0.65		
	23	0.77		
	24	0.60		

*SD: Standard Loading

3.3.3. Test of hypothesis

The dependent variable's volatility, p-values, and normalized path coefficients were produced by the SEM analysis, and these were used to determine the strength of the correlations between the variables. Figure 6 and Table 5 of the structural model display the findings. The results indicate that system quality and information quality both substantial impact user satisfaction ($p=0.049$ and $\beta=0.39$ for system quality,

p=0.169 and $\beta=0.28$ for information quality). The other side, information quality and service quality were both substantial impact use (p=0.001 and $\beta=0.84$ for information quality, p=0.127 and $\beta=0.31$ for service quality). However, the hypotheses that stated system quality is positively influencing use was not supported (p=0.950 and $\beta=-0.02$). Also, the hypotheses that stated service quality is positively influencing user satisfaction was not supported (p=0.779 and $\beta=0.0$). Furthermore, the author found that user satisfaction substantial impact perceived net benefit (p=0.136 and $\beta=0.54$), but use is shown to not substantial impact perceived net benefit (p=0.0938 and $\beta=-0.03$). According to the structural model, use and user satisfaction combined account for around 41% of the total variance in perceived net benefits, with user satisfaction having a higher direct impact than use. Additionally, the defining qualities (system, information, and service quality) collectively explain roughly 96% given the difference in user satisfaction and around 61% given the difference in use.

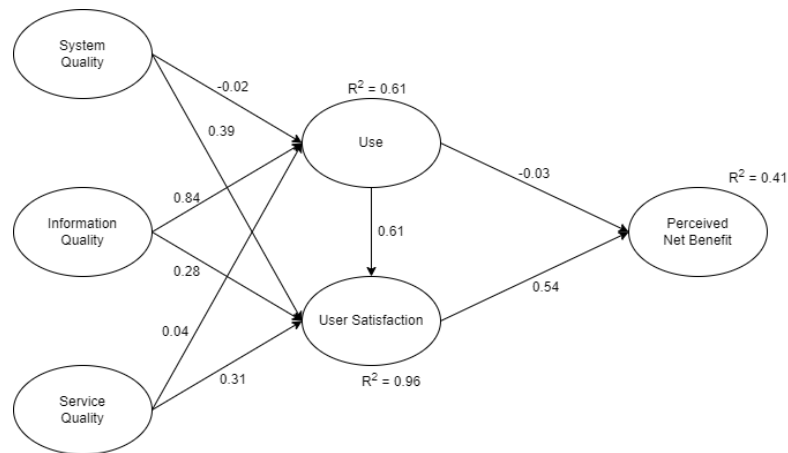

Figure 6. SEM in this research

Table 5. This research path coefficients

Path	β	p-value	Remarks
Use will gain from system quality (H1)	-0.02	0.950	Not supported
User satisfaction will gain from system quality (H2)	0.39	0.049	Supported
Use will gain from information quality (H3)	0.84	0.001	Supported
User satisfaction will gain from information quality (H4)	0.28	0.169	Supported
Use gain from service quality (H5)	0.31	0.127	Supported
User satisfaction will gain from service quality (H6)	0.04	0.779	Not supported
User satisfaction will gain from use (H7)	0.61	<0.001	Supported
Perceived net benefit will gain from use (H8)	-0.03	0.938	Not supported
Perceived net benefit satisfaction will gain from user (H9)	0.54	0.136	Supported

This research confirms the deLone and McLean approach in the perspective of ADLM utilized by several Indonesian banking companies. The model's structure and relationships were proved to be numerically important, except for the effect of use will gain from system quality (H1), user satisfaction will gain from service quality (H6), and perceived net benefit will gain from use (H8). However, notes need to be taken on the model's fit to the underlying data gathered from the available correspondents. Due to the limitations of data collection activity, the model fit indices show that there are several improvements that can be made on the fitness of the model compared to actual data collected in the context of ADLM adoption in the banking sector. However, as shown in the previous studies related to measuring net impact benefit, we can conclude that this model and its construct are good enough for measuring ADLM system success.

In general, this research showed that there exists a relationship between quality constructs of ADLM (system quality, information quality, and service quality) with system use and user satisfaction. This relationship then further affects the perceived net benefit of the ADLM. However, when we inspect specifically on each individual quality construct, we didn't find any proof that System Quality had a big impact on how ADLM was used. This outcome is consistent with the findings of several earlier investigations [38]–[40]. The results of this study, however, do not support several other investigations [40]–[42], which determine the effect of use will gain from system quality. (H1) of information systems. Interestingly, this study provides clear evidence that quality of information does significantly affect the use (H3) of the ADLM system, which also have been proved in other similar studies in other system contexts of

use [38]–[43]. This is a particularly important result, because it showed that in system use can be improved by improving the quality of information in the system. It is also worth mentioning that use gain from service quality (H5) of ADLM. While several previous research reported similar result [32], [38], [40], and the others research result are not [38], [41], [43].

The findings from this study showed that each individual quality construct contributes to user satisfaction. This result showed that to improve user satisfaction, an improvement of system quality, information quality, and service quality needs to be addressed importantly with no regards. This is very important, considering that user satisfaction has a more major impact on perceived net benefits than user satisfaction. Also, the quality dimensions (system, information, and service quality) are all were seriously impacted by user satisfaction with ADLM. This finding is consistent with those of earlier research projects carried out in the same area [32], [40], [43]. As final word, the success of ADLM in supporting strategic company projects can be quantitatively measured through the perceived net benefits of the system. Using the DeLone and McLean model, it is shown that in relation to Indonesian banking companies, user satisfaction is the major driver of perceived benefits of the ADLM system. On the other hand, this study provides clear evidence that quality dimension (system, information, and service quality) all significantly affects user satisfaction. Therefore, it is of the utmost importance to provide full attention to the overall quality of the system.

4. CONCLUSION

In conclusion, this study has verified the model in the environment of the ADLM Banking industry in Indonesia, according to DeLone and McLean's directive to iteratively test and improve their theory in various situations. This study has illustrated that system use is crucial indicator perceived net benefits, which eventually determine success. Furthermore, system quality has the greatest impact compared to all quality dimensions predict system use. Therefore, system quality properties like usability, functionality, and adaptability should receive more attention from ADLM product owners and project managers. There was a limitation on the kind of respondents who were polled, yet this does not cast some doubt on the study's findings. Once ADLM has reached a steady state of use, further research needs to poll all its users. Additionally, using a mixed methods approach may help to uncover more details about the effectiveness of the ADLM system. Adopting methods other than SEM for data processing, or processing with mixed methods to find out about the success of the ADLM system.

ACKNOWLEDGMENTS

Our sincere thanks go to the Magister of Technology Information, University of Indonesia, for facilitating this research. We also express our infinite thanks to several banks that became case studies in interviews and contributed to filling out the questionnaire. Support from 4 banks, BRI, BCA, CIMB Niaga and Bank Raya for filling out surveys and resource persons for interviews.

APPENDIX

Pertanyaan Jawaban 52 Setelan

Survey ADLM (Jira, Confluence, Bamboo, Bitbucket, dan Crowd)

Dear Mr/Mrs,

I am Noviana Pramisari and Irvan Ramadhan Zarkasie, Postgraduate students from the MTI Department, University of Indonesia, expecting your willingness to fill out this questionnaire. This questionnaire is a data retrieval tool in the preparation of our Corporate Information System Course assignment entitled "Net Impact Implementation Application Development Life-cycle Management (ADLM) in Banking Sector". The ADLM application here is the Atlassian Product consisting of Jira, Confluence, Bitbucket, Bamboo, and Crowd.

1. Before filling out this questionnaire, you should first read all the instructions for filling out and the questions in the assessment aspect carefully.
2. You are expected to answer all the questions, because your answers are very important and needed in this research.
3. Please choose the answer that you think is the most appropriate and please fill in the part that requires a written answer
4. Description of alternative answers and scores
 - SS = Strongly Agree (5)
 - S = Agree (4)
 - KS = Disagree (3)
 - TS = More Disagree (2)
 - STS = Strongly Disagree (1)

Questionnaire results

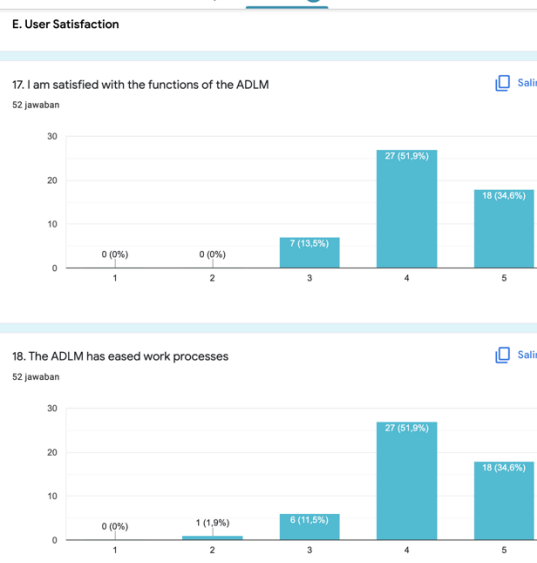



REFERENCES

- [1] P. Rozehnal and V. Novák, "Analysis of processes information flows and items as additional design factor in COBIT framework," *Central European Business Review*, vol. 10, no. 4, pp. 63–82, Sep. 2021, doi: 10.18267/j.cebr.264.
- [2] K. Crowston *et al.*, "Knowledge tracing to model learning in online citizen science projects," *IEEE Transactions on Learning Technologies*, vol. 13, no. 1, pp. 123–134, Jan. 2020, doi: 10.1109/lt.2019.2936480.
- [3] S. A. Al-Shami, A. K. M. S. Alsuwaidi, and S. Akmal, "The effect of entrepreneurial orientation on innovation performance in the airport industry through learning orientation and strategic alignment," *Cogent Business & Management*, vol. 9, no. 1, Jul. 2022, doi: 10.1080/23311975.2022.2095887.
- [4] N. Rizun, A. Revina, and V. G. Meister, "Analyzing content of tasks in business process management. Blending task execution and organization perspectives," *Computers in Industry*, vol. 130, p. 103463, Sep. 2021, doi: 10.1016/j.compind.2021.103463.
- [5] F. H. Rad and S. M. Rowzan, "Designing a hybrid system dynamic model for analyzing the impact of strategic alignment on project portfolio selection," *Simulation Modelling Practice and Theory*, vol. 89, pp. 175–194, Dec. 2018, doi: 10.1016/j.simpat.2018.10.001.
- [6] Y. Wautelet, "A model-driven IT governance process based on the strategic impact evaluation of services," *Journal of Systems and Software*, vol. 149, pp. 462–475, Mar. 2019, doi: 10.1016/j.jss.2018.12.024.
- [7] G. Cattaneo, U. F. Petrillo, R. Giancarlo, F. Palini, and C. Romualdi, "The power of word-frequency-based alignment-free functions: a comprehensive large-scale experimental analysis," *Bioinformatics*, vol. 38, no. 4, pp. 925–932, Oct. 2021, doi: 10.1093/bioinformatics/btab747.
- [8] I. Sommerville, *Engineering software products*. London: Pearson, 2020.
- [9] L. Chen, H. Liu, Z. Zhou, M. Chen, and Y. Chen, "IT-business alignment, big data analytics capability, and strategic decision-making: moderating roles of event criticality and disruption of COVID-19," *Decision Support Systems*, vol. 161, p. 113745, Oct. 2022, doi: 10.1016/j.dss.2022.113745.
- [10] H. Deng, Y. Xu, Y. Deng, and J. Lin, "Transforming knowledge management in the construction industry through information and communications technology: a 15-year review," *Automation in Construction*, vol. 142, p. 104530, Oct. 2022, doi: 10.1016/j.autcon.2022.104530.
- [11] F. Rahimi, C. Møller, and L. Hvam, "Business process management and IT management," *International Journal of Information Management*, vol. 36, no. 1, pp. 142–154, Feb. 2016, doi: 10.1016/j.ijinfomgt.2015.10.004.
- [12] I. B. Heredia-Marin, A. Tijerina-Berzosa, P. E. Vazquez-Badillo, R. Osorio-Oliveros, and C. Vazquez-Hurtado, "Work in progress: developing competencies by designing an adaptive automated storage and retrieval system using ROS," in *2022 IEEE World Engineering Education Conference (EDUNINE)*, Mar. 2022, pp. 1–4, doi: 10.1109/edunine53672.2022.9782352.
- [13] W. H. Money, S. H. Kaisler, and S. J. Cohen, "Understanding failed software projects through forensic analysis," *Journal of Computer Information Systems*, vol. 62, no. 5, pp. 940–953, Jul. 2021, doi: 10.1080/08874417.2021.1950076.
- [14] L. Almazydeh, M. Alsafasfeh, R. Alsalamdeen, and S. Alsharari, "Formalization of the prediction and ranking of software development life cycle models," *International Journal of Electrical and Computer Engineering (IJECE)*, vol. 12, no. 1, p. 534, Feb. 2022, doi: 10.11591/ijece.v12i1.pp534-540.
- [15] A. Ahmed and B. Prasad, *Foundations of software engineering*, 1st ed. Auerbach Publications, 2016.
- [16] I. Sommerville, "Software and professional development," *IEEE Software*, vol. 33, no. 2, pp. 90–92, Mar. 2016, doi: 10.1109/ms.2016.43.
- [17] R. A. Khan, S. U. Khan, H. U. Khan, and M. Ilyas, "Systematic literature review on security risks and its practices in secure software development," *IEEE Access*, vol. 10, pp. 5456–5481, 2022, doi: 10.1109/access.2022.3140181.
- [18] H. E. Yant'ir, A. M. Eltawil, and K. N. Salama, "A hardware/software co-design methodology for in-memory processors," *Journal of Parallel and Distributed Computing*, vol. 161, pp. 63–71, Mar. 2022, doi: 10.1016/j.jpdc.2021.10.009.
- [19] Y. Yang, X. Xia, D. Lo, T. Bi, J. Grundy, and X. Yang, "Predictive models in software engineering: challenges and opportunities," *ACM Transactions on Software Engineering and Methodology*, vol. 1, no. 1, pp. 1–35, Apr. 2022, doi: 10.1145/3503509.
- [20] F. Sarro, R. Moussa, A. Petrozziello, and M. Harman, "Learning from mistakes: machine learning enhanced human expert effort estimates," *IEEE Transactions on Software Engineering*, vol. 48, no. 6, pp. 1868–1882, Jun. 2022, doi: 10.1109/tse.2020.3040793.
- [21] P. Widharto, Z. Suhatman, and R. F. Aji, "Measurement of information technology governance capability level: a case study of PT Bank BBS," *TELKOMNIKA Telecommunication Computing Electronics and Control*, vol. 20, no. 2, pp. 296–306, Apr. 2022, doi: 10.12928/telkomnika.v20i2.21668.
- [22] A. A. Jan, F.-W. Lai, and M. Tahir, "Developing an Islamic corporate governance framework to examine sustainability performance in Islamic banks and financial institutions," *Journal of Cleaner Production*, vol. 315, p. 128099, Sep. 2021, doi: 10.1016/j.jclepro.2021.128099.
- [23] M. I. Lunesu, R. Tonelli, L. Marchesi, and M. Marchesi, "Assessing the risk of software development in agile methodologies using simulation," *IEEE Access*, vol. 9, pp. 134240–134258, 2021, doi: 10.1109/access.2021.3115941.
- [24] M. Kwapisz and M. Karbowanczyk, *Educational infrastructures for IT teaching*. Seria: Monografie, 2021.
- [25] A. E. E. Sobaih and A. M. Hasanein, "Herzberg's theory of motivation and job satisfaction: does it work for hotel industry in developing countries?," *Journal of Human Resources in Hospitality & Tourism*, vol. 19, no. 3, pp. 319–343, Mar. 2020, doi: 10.1080/15332845.2020.1737768.
- [26] W. H. DeLone and E. R. McLean, "Information systems success measurement," *Foundations and Trends® in Information Systems*, vol. 2, no. 1, pp. 1–116, 2016, doi: 10.1561/2900000005.
- [27] S. Michel, A. Michaud-Trévinal, and F. Cocula, "Net impacts in front office IS: a first operationalization of DeLone and McLean model in the banking sector," *Electronic Journal of Information Systems Evaluation*, vol. 22, no. 2, pp. 92–112, Nov. 2019, doi: 10.34190/ejise.19.22.2.003.
- [28] Ö. Sebetci and M. Çetin, "Developing, applying and measuring an e-prescription information systems success model from the perspectives of physicians and pharmacists," *Health Policy and Technology*, vol. 5, no. 1, pp. 84–93, Mar. 2016, doi: 10.1016/j.hlpt.2015.10.008.
- [29] W. H. DeLone and E. R. McLean, "Information systems success: the quest for the dependent variable," *Information Systems Research*, vol. 3, no. 1, pp. 60–95, Mar. 1992, doi: 10.1287/isre.3.1.60.
- [30] "The DeLone and McLean model of information systems success: a ten-year update," *Journal of Management Information Systems*, vol. 19, no. 4, pp. 9–30, Apr. 2003, doi: 10.1080/07421222.2003.11045748.
- [31] N. Urbach and B. Müller, "The updated DeLone and McLean model of information systems success," in *Information Systems Theory*, Springer New York, 2011, pp. 1–18.



- [32] B. Tilahun and F. Fritz, "Modeling antecedents of electronic medical record system implementation success in low-resource setting hospitals," *BMC Medical Informatics and Decision Making*, vol. 15, no. 1, Aug. 2015, doi: 10.1186/s12911-015-0192-0.
- [33] J. C. Barnes and D. R. Forde, Eds., "Measurement validity," *The Encyclopedia of Research Methods in Criminology and Criminal Justice*, Aug. 2021, doi: 10.1002/9781119111931.
- [34] B. M. Byrne, *Structural equation modeling with AMOS: basic concepts, applications, and programming*, Third. Routledge, 2016.
- [35] R. B. Kline, "Principles and practice of structural equation modeling by," *Structural Equation Modeling: A Multidisciplinary Journal*, Jul. 2016, doi: 10.1080/10705511.2012.687667.
- [36] S. El-Den, C. Schneider, A. Mirzaei, and S. Carter, "How to measure a latent construct: psychometric principles for the development and validation of measurement instruments," *International Journal of Pharmacy Practice*, vol. 28, no. 4, pp. 326–336, Jan. 2020, doi: 10.1111/ijpp.12600.
- [37] A. I. Ojo, "Validation of the DeLone and McLean information systems success model," *Healthcare Informatics Research*, vol. 23, no. 1, pp. 60–66, 2017, doi: 10.4258/hir.2017.23.1.60.
- [38] I. Brown and R. Jayakody, "B2C e-commerce success: a test and validation of a revised conceptual model," *Electronic Journal Information Systems Evaluation*, vol. 11, no. 3, pp. 167–184, 2008.
- [39] Y.-S. Wang and Y.-W. Liao, "Assessing eGovernment system success: a validation of the DeLone and McLean model of information systems success," *Government Information Quarterly*, vol. 25, no. 4, pp. 717–733, Oct. 2008, doi: 10.1016/j.giq.2007.06.002.
- [40] W. Choi, M. J. Rho, J. Park, K.-J. Kim, Y. D. Kwon, and I. Y. Choi, "Information system success model for customer relationship management system in health promotion centers," *Healthcare Informatics Research*, vol. 19, no. 2, pp. 110–120, 2013, doi: 10.4258/hir.2013.19.2.110.
- [41] S. Petter and A. Fruhling, "Evaluating the success of an emergency response medical information system," *International Journal of Medical Informatics*, vol. 80, no. 7, pp. 480–489, Jul. 2011, doi: 10.1016/j.ijmedinf.2011.03.010.
- [42] W.-Y. Jen and C.-C. Chao, "Measuring mobile patient safety information system success: an empirical study," *International Journal of Medical Informatics*, vol. 77, no. 10, pp. 689–697, Oct. 2008, doi: 10.1016/j.ijmedinf.2008.03.003.
- [43] K. W. Cho, S.-K. Bae, J.-H. Ryu, K. N. Kim, C.-H. An, and Y. M. Chae, "Performance evaluation of public hospital information systems by the information system success model," *Healthcare Informatics Research*, vol. 21, no. 1, p. 43, 2015, doi: 10.4258/hir.2015.21.1.43.

BIOGRAPHIES OF AUTHORS



Noviana Pramitasari    Bachelor of Computer Science from Bogor Agricultural University. A professional in the IT field as a senior manager in banking company. Experience in IT Treasury, International Business, Investment, Wholesale and Super Apps application as Programmer, System Analyst and Tester (Quality Assurance). Certified Agile Tester By International Software Testing Qualifications Board (ISTQB), Certified Data Management Professional (CDMP). Currently studying Master of Information Technology at the University of Indonesia. She can be contacted at email: noviana.pramitasari@ui.ac.id.



Yova Ruldeviyani, S.Kom., M.Kom    A lecturer and researcher at University of Indonesia, expert lecturer in Database and Data Management. Bachelor's and master's education from the University of Indonesia. Experience in Database, Data Manning, and Enterprise Resource Planning (ERP). She can be contacted at email: yova@cs.ui.ac.id.



Irvan Ramadhan Zarkasie    Currently a graduate student at the Faculty of Computer Science, University of Indonesia. Received his bachelor degree in information systems from University of Indonesia in 2016. Currently active as an enterprise application integration consultant in one of information technology consulting company in Jakarta, Indonesia. Throughout his six years of consulting practices, he has been handling various clients from different kind of industries, ranging from banking to telco businesses and public institutions. He can be contacted at email: irvan.ramadhan11@ui.ac.id.