

Circularly polarized metamaterial Antenna in energy harvesting wearable communication systems

Bala Inuwa¹, Olabode Idowu-Bismark², Oluseun Oyeleke¹, Jemitola Paul olugbeji³

¹Department of Computer Engineering, Nile University of Nigeria, Abuja, Nigeria

²Department of Electrical and Information Engineering, Covenant University, Ota, Nigeria

³Department of Electrical and Electronic Engineering, Nigerian Airforce institute of Technology, Kaduna

Article Info

Article history:

Received Dec 13, 2022

Revised May 28, 2023

Accepted Jun 7, 2023

Keywords:

Circularly polarized antenna

Green energy source

Metamaterials antenna

Radio frequency energy

harvesting module

Wireless sensors

ABSTRACT

When battery powered sensors are spread out in places that are sometimes hard to reach, sustaining them become difficult. Therefore, to develop this technology on a large scale such as in the internet of things (IoT) scenario, it is necessary to figure out how to power them. The proffered solution in this work, is to get energy from the environment using energy harvesting Antennas. This work presents a wearable circular polarized efficient receiving and transmitting sensors for medical, IoT, and communication systems at the frequency range of WLAN, and GSM from 900 MHz up to 6 GHz. Using a cascaded system block of a circularly polarized Antenna, a rectifier and t-matching network, the design was successfully simulated. A DC charging voltage of 2.8V was achieved to power-up batteries of the wearable and IoT sensors. The major contribution of this work is the tri-band Antenna system which is able to harvest reflected Wi-Fi frequencies and also GSM frequencies combined in a miniaturized manner. This innovative configuration is a step forward in building devices with over 80% duty cycle.

This is an open access article under the [CC BY-SA](https://creativecommons.org/licenses/by-sa/4.0/) license.



Corresponding Author:

Olabode Idowu-Bismark

Department of Electrical and Information Engineering, Covenant University

Canaan Land Ota, Nigeria

Email: idowubismarkolabode@gmail.com

1. INTRODUCTION

Commercially available wireless sensors in the communication industry are battery powered with limited lifespan to a certain number of cycles. It is difficult to maintain such sensors in remote locations. With the boom in the internet of things (IoT) it then become necessary to find solutions for energy supplies to the billions of such remotely located sensors. Energy harvesting Antennas comes as viable solution to providing such energy which will eliminate the necessity for maintaining or replacing batteries for those sensors, thereby increasing the sensors lifetime. Wireless sensors are used for body implant in the medical field as well as industrial sensors for industrial automation [1], [2]. In the medical field, this will optimize the use of wearable technologies. One of the upcoming technologies that can help solve the above power feeding problem is radio frequency (RF) energy harvesting [3]. Energy harvesting devices offer renewable energy and may remove the need for daily battery replacements. It is critical to collect electromagnetic power for a wide range of wireless communication systems to utilise as such free space energy is feasible. In these instances, ultra-wideband Antennas should be used [4], [5]. A programmable array with multiple Antennas can harvest energy from 100 MHz to 18 GHz. Figure 1 shows energy harvesting resources versus requirement.

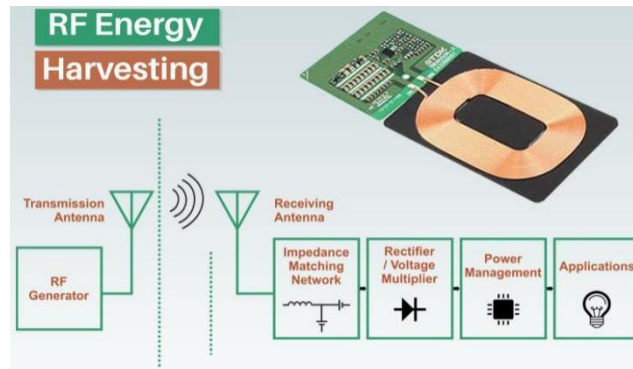

Figure 1. Energy harvesting

As a result of low-power electromagnetic energy densities in free space, it is necessary that energy harvesting Antenna meet certain requirements which include high efficiency, definite frequency operation range and polarization. Also, a wide beam or omni-directional radiation pattern is required for the Antenna [2]. Wideband printed compact slot and notch Antennas are excellent in their application for wideband energy harvesting systems as they are compact, low cost, flexible, and efficient. The electronic devices that are used in our daily lives have undergone significant changes over the past several decades along with the advancement of sensor technologies. Many strategies for generating electricity from these many sources of energy have been researched and developed [1], [2]. It is crucial to harvest the electromagnetic energy for a wide range of wireless communication systems in order to utilize the maximum amount of free space energy. For energy collecting applications, several printed Antennas have been used [6]. In communication and medical systems, patch and slot Antennas are frequently employed, wideband printed small slot and notch Antennas became excellent solutions for wideband energy harvesting devices. The system RF components and the Antennas can also be integrated on the same substrate to create a small, low-cost energy harvesting network and matching network [7]. In this study, high efficiency circular polarized Antennas with energy collecting units are designed for communication, IoT applications, 5G applications, and healthcare sensors.

In circular polarization, the electric field of the light contains two linear components that are perpendicular to one another, equal in amplitude, but differ by a phase of $\Pi/2$. This is known as circular polarization. The plane of polarization revolves in a corkscrew pattern, producing one full rotation for each wavelength in a circularly polarized Antenna. Energy is emitted by a circularly polarized wave in all planes, including the horizontal, the vertical, and any plane in between [8]. Right-hand circular (RHC) is the sense when the rotation is clockwise and looking in the direction of propagation. Left-hand circular (LHC) is the term for the feeling when the rotation is counter clockwise. Figure 2 shows the circular polarization pattern.

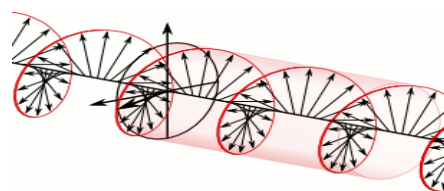

Figure 2. Circular polarization pattern

For 5G, IoT, and healthcare applications, wearable circular polarized patch Antennas with concentric complementary split ring resonators (CSRRs) were created [9], [10]. The new sensors' bandwidth ranges from 10% to 20% for voltage standing wave ratio (VSWR) better than 3:1. The Antennas with CSRRs have a gain of about 8 dB. The sensor's effectiveness is greater than 90%. Self-powered, effective, and small sensors are provided by the energy harvesting modules coupled to the sensors. Table 1 compares research on power-harvesting Antennas that has been published.

The core concept of metamaterial design is to craft materials by using artificially designed and fabricated structural units to achieve the desired properties and functionalities. The use of metamaterials in Antenna design greatly reduce the size of the Antenna and also improve the Antenna characteristics, such as enhancing bandwidth, increasing gain, and helping to produce multiband frequencies for an Antenna's

operation. This miniaturization is achieved by employing concentric complementary split ring resonator (CSRR) structures in between the patch and ground plane. Recently, there has been a lot of interest in the demand for the miniaturization and integration of various telecommunication equipment functions, particularly for items that are used frequently in daily life like mobile communication systems, smart phones, portable tablets, global positioning system receivers, and wireless internet devices. The mobile device's components must be portable and able to operate across many frequency bands to meet this criterion. One of them is an Antenna, which has to fit into the device, and is expected to be smaller than the gadget itself. Metamaterials can be used in Antenna designs to increase the radiated power of an Antenna. The most recent metamaterial Antennas may radiate up to 95% of a radio signal's input. For effective operation, standard Antennas must be at least half the wavelength of the transmission. An Antenna would need to be half a meter long, for example, at 300 MHz. The size of experimental metamaterial Antennas, in comparison, has been reduced to one-fiftieth of a wavelength and could be further reduced. Microwave Antennas can be further miniaturized with effective power and tolerable bandwidth thanks to metamaterials. Metamaterial-based Antennas have the potential to overcome constrictive efficiency-bandwidth constraints for traditionally built, tiny Antennas. The use of metamaterials enables smaller Antenna elements to cover a broader frequency range.

Table 1. Various power-harvesting Antennas and their characteristics

Ref.	Antenna Type	Gain	Frequency	Dimension (mm)	RF-DC PCE
[11]	Air-substrate patch	7 dBi	2.45 GHz	261×5	30% at 1 μ W/cm ²
[12]	Polarization patch		5.1–5.8 GHz	90×160	23.8%–31.9%
			5.8–6.1 GHz		22.7%–24.5%
[13]	Patch		2.45 GHz	100×70	73.9% at 207 μ W/cm ²
[14]	Dual-linearly polarized patch	7.45–7.63 dBi	2.45 GHz	70×47.5	78% at 295.3 μ W/cm ²
[15]	Microstrip	5.3 dBi	160 GHz	–	8.5% at –2.46 dBm
[16]	Patch		1.9–3.2 GHz	40×40×0.8	70% at 50 μ W/cm ²
[17]	Patch	–20.20 dBi	0.915 GHz	Π ×6×1.584	~ 60%
[18]	Patch, metal strip	4.33 dBi	4.9 GHz	68×34	65.2%
		6.64 dBi	5.9 GHz		64.8%
[19]	Stack differential		5.8 GHz	120×40	44.1% at 0.041 W/m ²
[20]	Dual-polarized patch		2.45 GHz	100×100×3.8	82.3% at 22 dBm
[21]	1×4 quasi-Yagi	10.9 dBi	1.8 GHz	300×300×1.6	40% at 455 μ W/cm ²
		13.3 dBi	2.2 GHz		
[22]	Dipole	–	0.915 GHz	60×60×60	48% at 0 dBm
			2.45 GHz		39% at 0 dBm
[23]	Microstrip	8.6 dBi	2.45 GHz	–	83%
[24]	Patch	4 dBi	2.45 GHz	–	70%
[25]	Patch	2.19 dBi	2.45 GHz	40×43	65% at 10 mW/cm ²
		3.6 dBi	5.8 GHz		46% at 10 mW/cm ²

The circular patch Antenna with complementary split ring resonators (CSRRs) can be utilized as a sensor. The Antenna effective area and gain are enhanced by the CSRRs. A branch line coupler, a harvesting device, and a circular stacked patch make up the sensor. A resonator and a corresponding feed network are printed on the first layer of the circular stacked patch. On the second layer, the circular radiator with the CSSR is printed. Radiator is excited by the resonator using electromagnetic coupling. A circular polarized Antenna is produced by the circular patch being driven by the branch line coupler. When the switch is linked to the harvesting unit, the RF dual mode energy harvesting unit may replenish the battery. A rectifying diode converts electromagnetic power into DC power. Figure 3 shows a single CSRR.

Other authors have reviewed various energy harvesting technologies such as the author of [23] which compared energy harvesting systems from various energy sources. The paper provides an overview of the various energy harvesting technologies for IoT devices that serve as the context for the researchers engaged in this field. The authors of [24] investigate various sources and frequency ranges for effective energy harvesting and conclude that the medium wave frequency band, 531-1,611 kHz, has the most effective operating range. An Antenna, LC tuning circuit, 5-stage Villard voltage multiplier circuit, and super-capacitor are used in the experiment as energy storage devices. An RF signal with a field strength of 103.724 dBu could be captured by the experiment from a transmitter that is located one mile away. The storage capacitor's maximum charge, which was measured, was 2.8V. The huge size of the Antenna, which restricts its portability, is a restriction of using this range of frequencies. The authors of [12]–[14], and [25], [26] investigate various sources for energy harvesting and conclude that RF waves energy harvesting is the best option in many circumstances for low-energy IoT devices. The studies in [11] and [23] emphasize the potential of RF energy harvesters (RFEHs) to power IoT devices for monitoring the environment and

healthcare. Other methods for extracting energy from RF signals include exchanging energy amongst neighbouring wireless systems [24] or opportunistic charging from nearby cell phones. The author of [27] proposed a brand-new Wi-Fi 802.11 b/g band operating system for radio frequency (RF) energy harvesting. The technology described in this paper delivers good power conversion efficiencies (PCEs) at a power range that ranges from (-20 dBm) to (3 dBm). The designed rectenna's rectification process is driven by a directive slot Antenna. The author of [28] describes RF energy harvesting as well as the design and Antenna optimization needed for the energy harvesting. At frequency 1,800 MHz, the designed Antenna has a gain of 4 dBi (i.e. GSM 1,800 mobile band). In the work of [29], the author researched RF energy harvesting at 2.45 GHz utilizing a rectifier and a rectenna Antenna. A rectangular microstrip inset-fed patch is created. A straightforward rectifier circuit that uses Schottky diodes (HSMS-2850) to convert Antenna AC power into DC for RF detection. High frequency simulator is used to analyse the design and specifications of the Antenna, including gain, directivity, return loss, voltage standing wave ratio (VSWR), and input impedance (HFSS). The authors of [30] designed an ultra-wideband (UWB) cylindrical metamaterial Antenna for RF energy harvesting for IoT applications. The patch circuitry is a 3×5 Hilbert-shaped metamaterial unit cells array which enhances the Antenna bandwidth while the Antenna gain is enhanced with the Antenna ground plane being defected with an electromagnetic band gap structure. In the work of [31], organic materials are used for harvesting RF-energy where palm tree fragments are combined with nickel oxide nanoparticles accommodated in polyethylene, Indium Phosphide substrates. A metamaterial Antenna is afterward reproduced on the created Indium Phosphide substrates of 0.8 mm depth by means of silver nanoparticles conductive ink. The Antenna produced performed with an ultra-wide band matching bandwidth that ranges from 2.4 GHz to 10 GHz frequency with bore-sight gain variation from 2.2 dBi to 3.43 dBi at maximum.

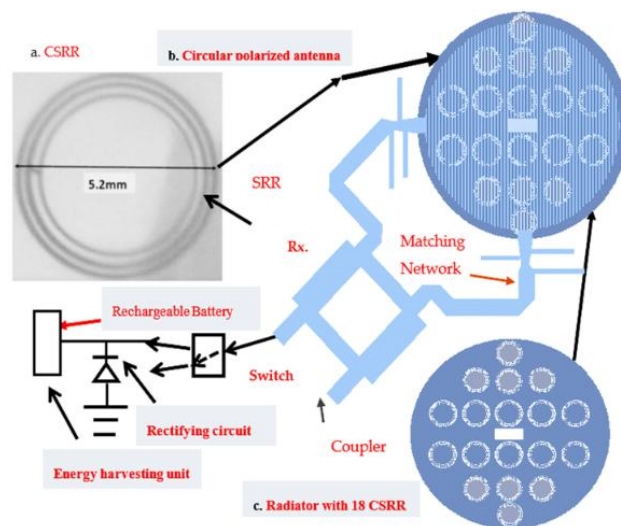

Figure 3. Circular patch Antenna showing: (a) Single complementary split ring resonators (CSRR), (b) A sensor and harvester with circular polarization, and (c) The radiator

2. METHOD

This section describes the detailed procedures and methods that was employed for the successful completion of this research. We present the Antenna design and simulation results obtained with MATLAB and HFSS. The list of materials that was used for this research and the steps of the methodology adopted for this research. Table 2 shows the Antennas and their operating frequencies. Figure 4 shows the conceptual block diagram of the RF energy harvesting module, while Figure 5 shows the three different energy harvesting modules operating at three different operating frequencies. Figure 6 is the flow chart of the design of the patch Antennas using 3D high frequency simulation software (HFSS). Table 2 shows the three Antennas operating at three different frequencies.

Table 2. Antenna operating frequencies

Antenna	Frequency
1	2.4 GHz
2	5.8 GHz
3	930 MHz

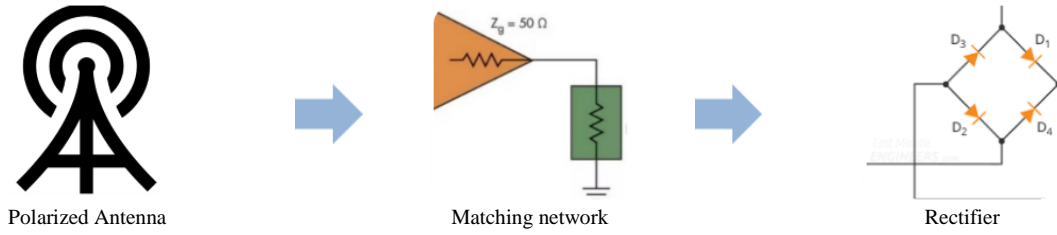

Figure 4. Conceptual RF energy harvesting module

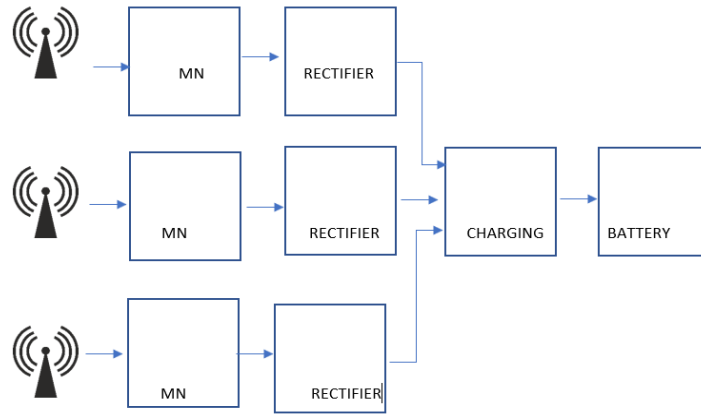

Figure 5. Conceptual RF energy harvesting module

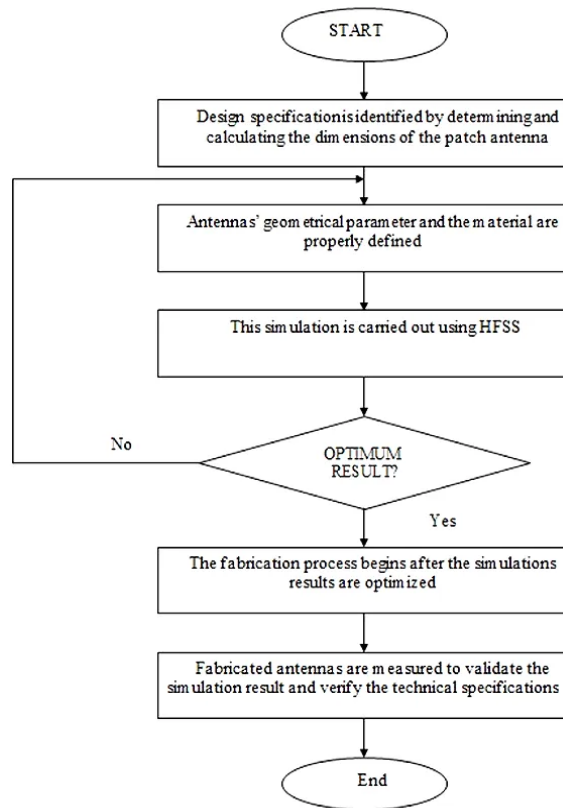

Figure 6. The flow chart of the design of the patch Antennas
Materials used are: i) Dell Latitude E6530; ii) MATLAB 2018; and iii) ADS Keysight 2019.

3.1. Design of Antenna 1

In Table 5, we show the parameters used for the design of Antenna 1, which include the radius, height and the substrate thickness. In Figure 8 we show the circular patch Antenna design. Figure 9 shows the S11 parameter of Antenna 1 which is sometimes referred to as the reflection coefficient

Table 5. Parameter of design for Antenna 1

Parameter	Value
Radius	0.036849
Height	0.0024983
Ground Plane Length	0.12491
Ground Plane Width	0.12491
Feed offset	[-0.018425 0]
Substrate Thickness	0.0024983

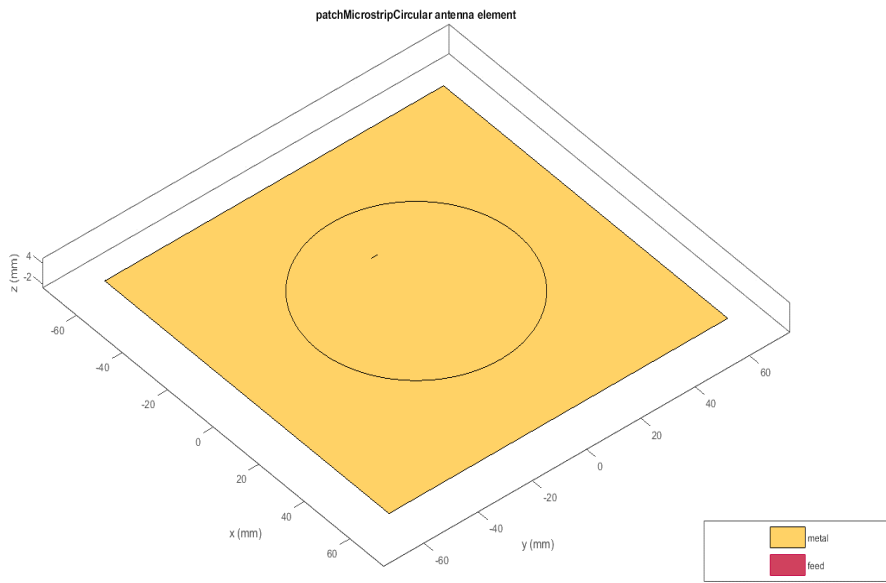

Figure 8. Circular patch Antenna design

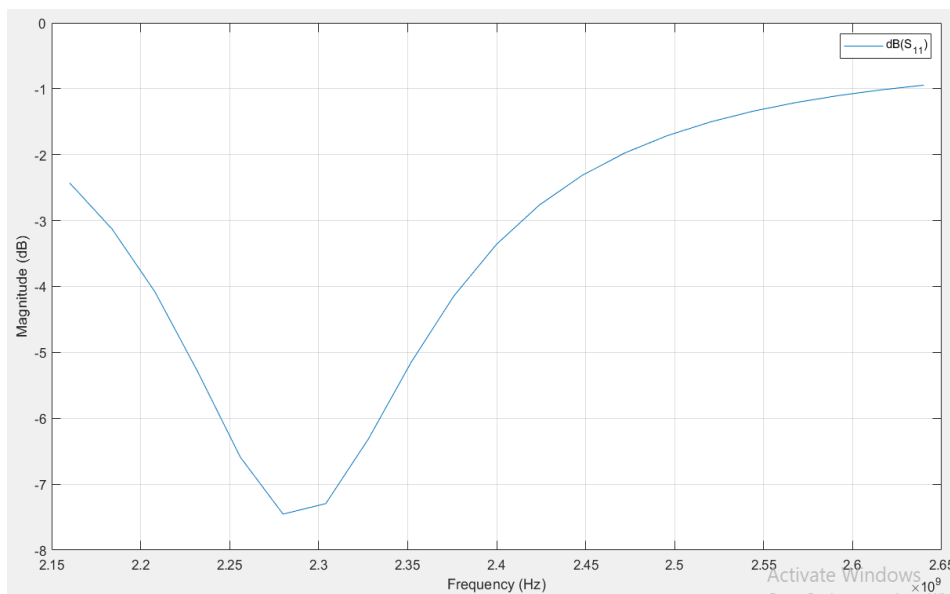

Figure 9. S11 parameter of Antenna 1

Typically, a vector network analyzer (VNA), which can plot S11, would be used to measure the aforementioned. According to the aforementioned graph, the Antenna radiates most effectively around 2.5 GHz, where S11 = -10 dB. Additionally, the Antenna will emit almost nothing at 2.2 GHz because S11 is near to 0 dB. (So, all the power is reflected). The radiation pattern of Antenna 1 is shown in Figure 10 and Figure 11. The azimuth and elevation are shown in Figure 12 and Figure 13. The isotropic power radiation values are shown in Table 6.

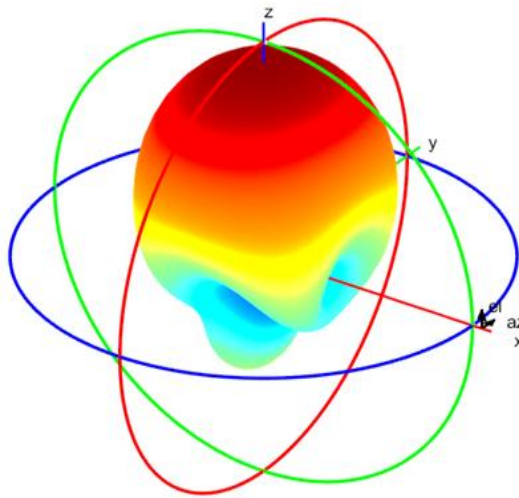

Figure 10. Radiation pattern of Antenna 1

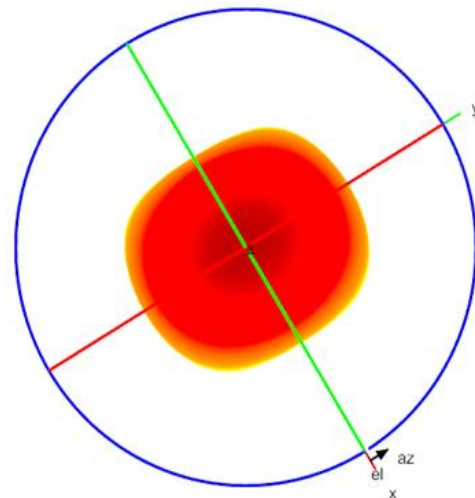

Figure 11. Radiation pattern of Antenna 1

Table 6. Isotropic power radiation value

Parameter	Value
Output	Directivity
Frequency	2.4 GHz
Max value	9.68 dBi
Min value	-19.5 dBi

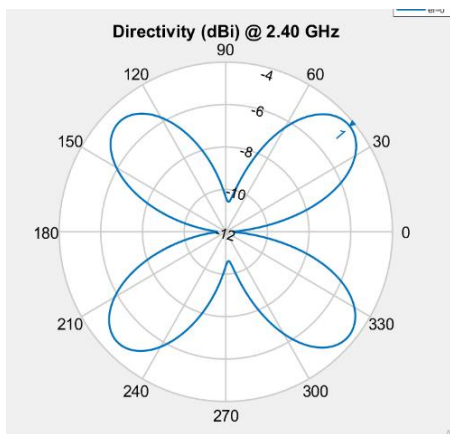

Figure 12. Azimuth of Antenna 1

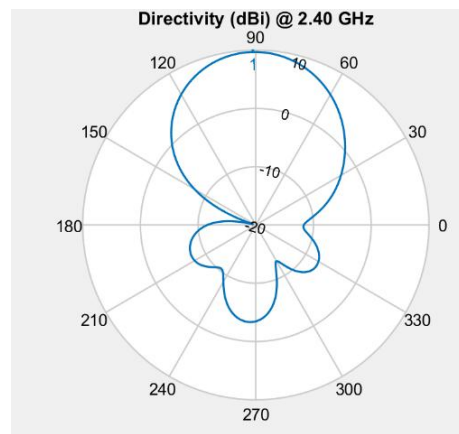

Figure 13. Elevation of Antenna 1

3.2. Design of Antenna 2

In Table 7, we presented the parameters used for the design of Antenna 2 which include the radius, height and the substrate thickness. Figure 14 shows the resistance and reactance parameter of the Antenna. Figure 15 shows the S11 parameter of Antenna 2 which is sometimes referred to as the reflection coefficient.

Table 7. Parameter of design of Antenna 2

Parameter	Value
Radius	0.015248
Height	0.0010338
Ground Plane Length	0.051688
Ground Plane Width	0.051688
Feed offset	[-0.007624 0]
Substrate Thickness	0.0010338

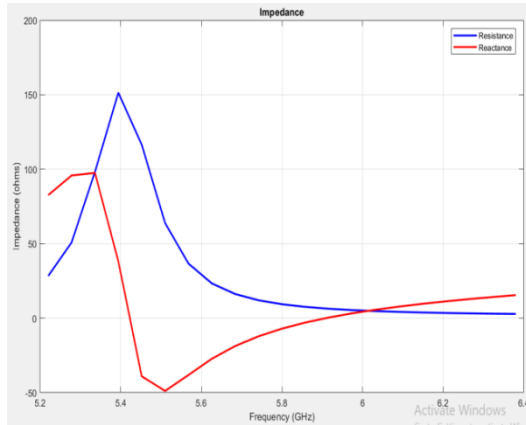

Figure 14. Resistance and reactance parameter of Antenna 2

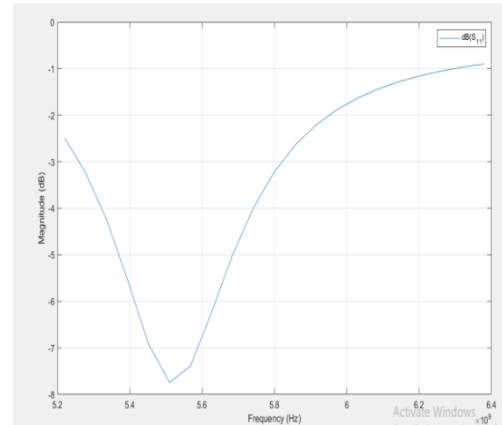

Figure 15. S11 parameter of Antenna 2

A VNA, which can plot S11, would be used to measure the aforementioned. According to the graph, the Antenna radiates most effectively around 6 GHz, where S11=-10 dB. Additionally, the Antenna will emit almost nothing at 2.2 GHz because S11 is near to 0 dB. (so, all the power is reflected). The radiation pattern of Antenna 2 is shown in Figure 16 and Figure 17. The azimuth and elevation are shown in Figure 18 and Figure 19 while Table 8 is the isotropic power radiation value of Antenna 2

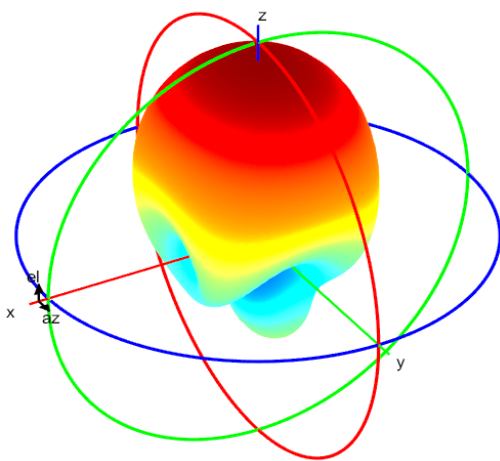

Figure 16. Radiation pattern of Antenna 2

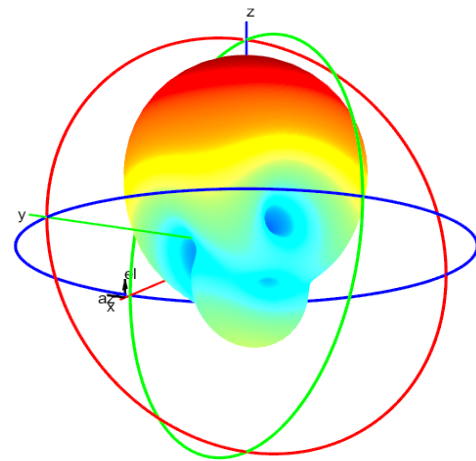

Figure 17. Radiation pattern of Antenna 2

Table 8. Isotropic power radiation value of Antenna 2

Parameter	Value
Output	Directivity
Frequency	5.8 GHz
Max value	9.67 dBi
Min value	-19.2 dBi

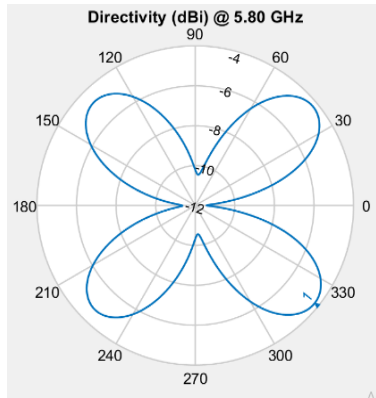

Figure 18. Azimuth of Antenna 2

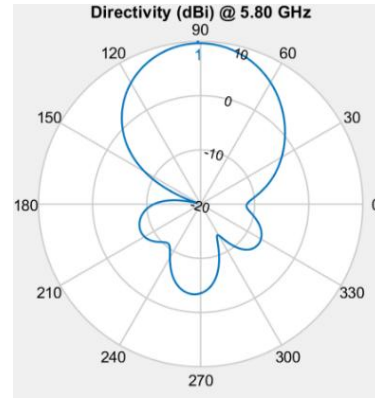

Figure 19. Elevation of Antenna 2

3.3. Design of Antenna 3

In Table 9, we show the parameters used for the design of Antenna 3 which include the antenna radius, height and substrate thickness. Figure 20 shows the resistance and reactance parameter of Antenna 3. Figure 21 shows the S11 parameter of Antenna 3 which is sometimes referred to as the reflection coefficient.

Table 9. Parameter of design of Antenna 3

Parameter	Value
Radius	0.095095
Height	0.32236
Ground Plane Length	0.32236
Ground Plane Width	0.051688
Feed offset	[-0.047548 0]
Substrate Thickness	0.0064471

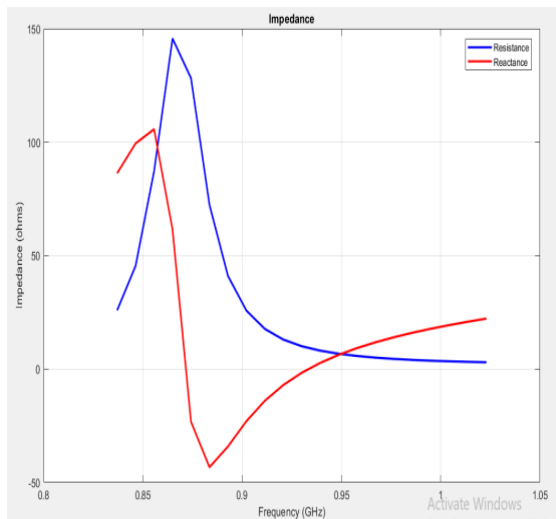

Figure 20. Resistance and reactance of Antenna 3

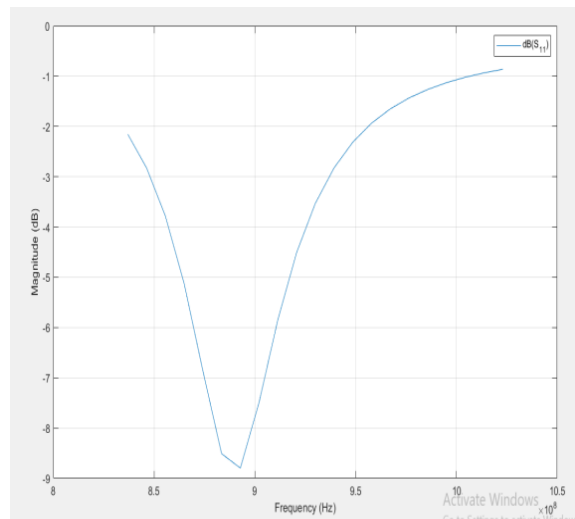

Figure 21. S11 Parameter of Antenna 3

A VNA, which can plot S11, would be used to measure the aforementioned. According to the graph, the Antenna radiates most effectively around 6 GHz, where S11=-10 dB. Additionally, the Antenna will emit almost nothing at 2.2 GHz because S11 is near to 0 dB. (so, all the power is reflected). The radiation pattern of Antenna 3 is shown in Figure 22. The azimuth and elevation are shown in Figure 23 and Figure 24. Table 10 is the radiation of isotropic power of Antenna 3.

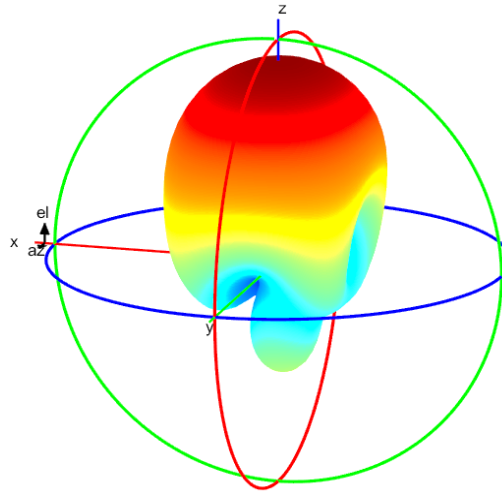

Figure 22. Radiation pattern of Antenna 3

Table 10. Radiation of isotropic power of Antenna 3

Parameter	Value
Output	Directivity
Frequency	930 MHz
Max value	9.65 dBi
Min value	-19.2 dBi

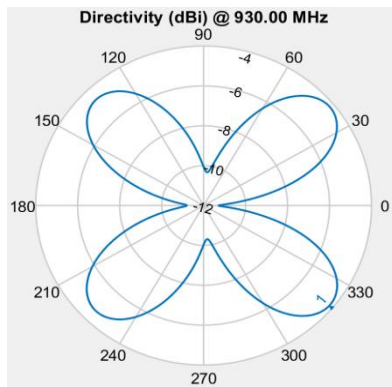

Figure 23. Azimuth of Antenna 3

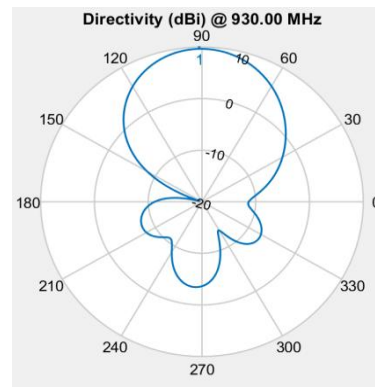

Figure 24. Elevation of Antenna 4

3.4. Impedance matching

In essence, matching circuits use coils and capacitors to match the Antenna impedance to the rectifier circuit to maximize power and increase efficiency. There are numerous matching circuits possible, but the transformer, parallel coil, and LC network, are the primary configurations that have been suggested. In (1) is used for impedance matching to transform s_{11} into complex impedances for matching. Table 11 shows the Antennas and their respective s_{11} (dB) parameter and the corresponding impedances.

$$Z_{in} = \frac{50(1+S_{11})}{(1-S_{11})} \tag{1}$$

Table 11. Antennas s_{11} parameter and the corresponding impedances

	S_{11} (dB)	Impedance transformation
Antenna 1	-7.5	-38.24+j0
Antenna 2	-7.7	-38.51+j0
Antenna 3	-8.8	-39.80+j0

4. CONCLUSION

In this work, a novel receiving triple Antenna for three-band RF energy harvesting systems is implemented. The results show that the suggested Antenna performs well overall at the required frequency range where at 930 MHz, the S11 is -7.5 dB, at 2.4 GHz, the S11 is -7.7 dB and at 5.8 GHz, the S11 is -8.8 dB: return loss is better than 20 dB, impedance is close to 50, and radiation patterns are nearly omnidirectional. The simulated and measured results show good agreement, which satisfies the final application's requirement.

REFERENCES





- [1] J. A. Paradiso and T. Starner, "Energy scavenging for mobile and wireless electronics," *IEEE Pervasive Comput.*, vol. 4, no. 1, pp. 18–27, 2005, doi: 10.1109/MPRV.2005.9.
- [2] C. R. Valenta and G. D. Durgin, "Harvesting wireless power: Survey of energy-harvester conversion efficiency in far-field, wireless power transfer systems," *IEEE Microw. Mag.*, vol. 15, no. 4, pp. 108–120, 2014, doi: 10.1109/MMM.2014.2309499.
- [3] J. W. Judy, "Microelectromechanical systems (MEMS): Fabrication, design and applications," *Smart Mater. Struct.*, vol. 10, no. 6, pp. 1115–1134, 2001, doi: 10.1088/0964-1726/10/6/301.
- [4] L. Chettri and R. Bera, "A comprehensive survey on internet of things (IoT) toward 5G wireless systems," *IEEE Internet Things J.*, vol. 7, no. 1, pp. 16–32, 2020, doi: 10.1109/JIOT.2019.2948888.
- [5] M. Zhu, T. He, and C. Lee, "Technologies toward next generation human machine interfaces: From machine learning enhanced tactile sensing to neuromorphic sensory systems," *Appl. Phys. Rev.*, vol. 7, no. 3, 2020, doi: 10.1063/5.0016485.
- [6] K. K. A. Devi, S. Sadasivam, N. M. Din, and C. K. Chakraborty, "Design of a 377 Ω patch antenna for ambient RF energy harvesting at downlink frequency of GSM 900," *17th Asia-Pacific Conf. Commun. APCC 2011*, pp. 492–495, 2011, doi: 10.1109/APCC.2011.6152859.
- [7] L. Liu, X. Guo, and C. Lee, "Promoting smart cities into the 5G era with multi-field internet of things (IoT) applications powered with advanced mechanical energy harvesters," *Nano Energy*, vol. 88, 2021, doi: 10.1016/j.nanoen.2021.106304.
- [8] I. Nadeem *et al.*, "A comprehensive survey on 'circular polarized antennas' for existing and emerging wireless communication technologies," *J. Phys. D. Appl. Phys.*, vol. 55, no. 3, 2022, doi: 10.1088/1361-6463/ac2c36.
- [9] L. G. Tran, H. K. Cha, and W. T. Park, "RF power harvesting: A review on designing methodologies and applications," *Micro Nano Syst. Lett.*, vol. 5, no. 1, 2017, doi: 10.1186/s40486-017-0051-0.
- [10] O. Oyeleke Wikiman, O. Idowu-Bismark, O. Ilesanmi, S. Thomas, and D. Charles Bala, "PIFA Antenna Design for MmWave Body Centric 5G Communication Applications," 2019. [Online]. Available: <http://www.internationaljournalssrg.org>
- [11] P. Momenroodaki, R. D. Fernandes, and Z. Popovic, "Air-substrate compact high gain rectennas for low RF power harvesting," *2016 10th Eur. Conf. Antennas Propagation, EuCAP 2016*, 2016, doi: 10.1109/EuCAP.2016.7481799.
- [12] P. Lu, X. S. Yang, J. L. Li, and B. Z. Wang, "Polarization reconfigurable broadband rectenna with tunable matching network for microwave power transmission," *IEEE Trans. Antennas Propag.*, vol. 64, no. 3, pp. 1136–1141, 2016, doi: 10.1109/TAP.2016.2518198.
- [13] H. Sun, "An enhanced rectenna using differentially-fed rectifier for wireless power transmission," *IEEE Antennas Wirel. Propag. Lett.*, vol. 15, pp. 32–35, 2016, doi: 10.1109/LAWP.2015.2427197.
- [14] P. Zhu, Z. Ma, G. A. E. Vandenbosch, and G. Gielen, "160 GHz harmonic-rejecting antenna with CMOS rectifier for millimeter-wave wireless power transmission," *2015 9th Eur. Conf. Antennas Propagation, EuCAP 2015*, pp. 1–5, 2015.
- [15] J. Zhang, Z. P. Wu, C. G. Liu, B. H. Zhang, and B. Zhang, "A double-sided rectenna design for RF energy harvesting," *2015 IEEE Int. Wirel. Symp. IWS 2015*, 2015, doi: 10.1109/IEEE-IWS.2015.7164617.
- [16] M. K. Hosain, A. Z. Kouzani, M. F. Samad, and S. J. Tye, "A miniature energy harvesting rectenna for operating a head-mountable deep brain stimulation device," *IEEE Access*, vol. 3, pp. 223–234, 2015, doi: 10.1109/ACCESS.2015.2414411.
- [17] P. Lu, X. S. Yang, J. L. Li, and B. Z. Wang, "A compact frequency reconfigurable rectenna for 5.2- and 5.8-GHz wireless power transmission," *IEEE Trans. Power Electron.*, vol. 30, no. 11, pp. 6006–6010, 2015, doi: 10.1109/TPEL.2014.2379588.
- [18] T. Matsunaga, E. Nishiyama, and I. Toyoda, "5.8-GHz stacked differential rectenna suitable for large-scale rectenna arrays with DC connection," *IEEE Trans. Antennas Propag.*, vol. 63, no. 12, pp. 5944–5949, 2015, doi: 10.1109/TAP.2015.2491319.
- [19] J. H. Chou, D. B. Lin, K. L. Weng, and H. J. Li, "All polarization receiving rectenna with harmonic rejection property for wireless power transmission," *IEEE Trans. Antennas Propag.*, vol. 62, no. 10, pp. 5242–5249, 2014, doi: 10.1109/TAP.2014.2340895.
- [20] H. Sun, Y. X. Guo, M. He, and Z. Zhong, "A dual-band rectenna using broadband yagi antenna array for ambient rf power harvesting," *IEEE Antennas Wirel. Propag. Lett.*, vol. 12, pp. 918–921, 2013, doi: 10.1109/LAWP.2013.2272873.
- [21] K. Niotaki, S. Kim, S. Jeong, A. Collado, A. Georgiadis, and M. M. Tentzeris, "A compact dual-band rectenna using slot-loaded dual band folded dipole antenna," *IEEE Antennas Wirel. Propag. Lett.*, vol. 12, pp. 1634–1637, 2013, doi: 10.1109/LAWP.2013.2294200.
- [22] H. Sun, Y. X. Guo, M. He, and Z. Zhong, "Design of a high-efficiency 2.45-GHz rectenna for low-input-power energy harvesting," *IEEE Antennas Wirel. Propag. Lett.*, vol. 11, pp. 929–932, 2012, doi: 10.1109/LAWP.2012.2212232.
- [23] U. Olgun, C. C. Chen, and J. L. Volakis, "Wireless power harvesting with planar rectennas for 2.45 GHz RFIDs," *Symp. Dig. - 20th URSI Int. Symp. Electromagn. Theory, EMTS 2010*, pp. 329–331, 2010, doi: 10.1109/URSI-EMTS.2010.5637008.
- [24] O. Bjorkqvist, O. Dahlberg, G. Silver, C. Kolitsidas, O. Quevedo-Teruel, and B. L. G. Jonsson, "Wireless sensor network utilizing radio-frequency energy harvesting for smart building applications [Education corner]," *IEEE Antennas Propag. Mag.*, vol. 60, no. 5, pp. 124–136, 2018, doi: 10.1109/MAP.2018.2859196.
- [25] M. Awais, S. Rehman, M. Asif, M. R. Usman, and S. Y. Shin, "RF energy harvesting for low power applications using rectenna operating at 2.45 GHz," in *2019 International Conference on Information and Communication Technology Convergence (ICTC)*, Oct. 2019, vol. 21, no. 1, pp. 789–793, doi: 10.1109/ICTC46691.2019.8940014.
- [26] O. A. Ilesanmi, C. U. Ndujiuba, and O. Idowu-bismark, "State of the Art Techniques for Cognitive Radio Antenna Design," vol. 9, no. 1, pp. 7–13, 2019, doi: 10.5923/j.ijea.20190901.02.
- [27] A. Eid *et al.*, "An efficient RF energy harvesting system," *2017 11th Eur. Conf. Antennas Propagation, EUCAP 2017*, pp. 896–899, 2017, doi: 10.23919/EuCAP.2017.7928573.
- [28] M. Kurvey and A. Kunte, "RF energy harvesting system," *2018 Int. Conf. Smart City Emerg. Technol. ICSCET 2018*, 2018, doi: 10.1109/ICSCET.2018.8537306.
- [29] P. Aminov and J. P. Agrawal, "RF energy harvesting," *Proc. - Electron. Components Technol. Conf.*, pp. 1838–1841, 2014, doi:

10.1109/ECTC.2014.6897549.

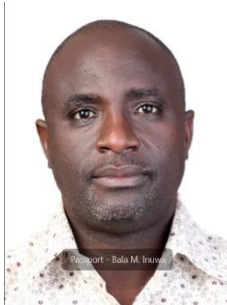



- [30] T. A. Elwi, D. A. Jassim, and H. H. Mohammed, "Novel miniaturized folded UWB microstrip antenna-based metamaterial for RF energy harvesting," *Int. J. Commun. Syst.*, vol. 33, no. 6, 2020, doi: 10.1002/dac.4305.
- [31] T. A. Elwi, Z. A. A. Hassain, and O. A. Tawfeeq, "Hilbert metamaterial printed antenna based on organic substrates for energy harvesting," *IET Microwaves, Antennas Propag.*, vol. 13, no. 12, pp. 2185–2192, 2019, doi: 10.1049/iet-map.2018.5948.

BIOGRAPHIES OF AUTHORS







Bala Inuwa     studied in FUT Minna and studies electrical engineering, he undertook his master's in electrical engineering from the Nile university of Nigeria. He works with the Nigeria Communication commission. His's area of specialty is Antennas, energy harvesting and communication. He can be contacted at email: inubala@gmail.com.







Olabode Idowu-Bismark     holds a B.Eng. Electrical and Electronics Engineering from the University of Benin, in Nigeria. M.Sc degree in Telecommunications Engineering from Birmingham University UK and a Ph.D in Information and Communication Engineering from Covenant University, Ota, Nigeria. Olabode has worked in various companies including Logic Sciences Limited, Basscomm Limited and Primotek Systems Limited as a engineer, project manager and executive director. He is a member of the Nigerian Society of Engineers, MIEEE, and a COREN Registered Engineer. His research interest is in the area of mobile communication, mmWave, and MIMO communication. He has published many scientific papers in international peer-reviewed journals and conferences. He can be contacted at email: idowubismarkolabode@gmail.com.



Oluseun D. Oyeleke     is a lecturer 1 at the Nile University of Nigeria. He is a graduate of Electrical engineering from Bayero University Kano and also has his Meng from the Nigeria Defence Academy in Electronics and communications. His research interest is in the areas of microwave technology, solid-state electronics, and machine learning for telecommunication and health applications. He can be contacted at email: oluseun.oyeleke@nileuniversity.edu.ng, contactseun@gmail.com.



Jemitola Paul Olugbeji     attended the Armed Forces Command and Staff College Jaji for his junior and senior staff courses. He has a master's degree in Aerospace Vehicle Design and a PhD in Aerospace Engineering, both from Cranfield University, United Kingdom. He is an Associate Professor of Aerospace Engineering and a Fellow of the National Defense College. AVM Jemitola was the lead designer of the Tsaigumi Unmanned Aerial Vehicle (UAV) and has been involved in several R&D projects within and outside Nigeria.