

Self-quadplexing slot antenna for S and C-band applications

Padmini Nigam¹, Arjuna Muduli², Sandeep Sharma³, Amrindra Pal¹

¹Department of Electronics and Communication Engineering, DIT University, Dehradun, India

²Department of Electronics and Communication Engineering, Koneru Lakshmaiah Education Foundation, Andhra Pradesh, India

³Department of Electronics and Communication Engineering, Chang Gung University, Taoyuan, Taiwan

Article Info

Article history:

Received Jan 12, 2022

Revised Apr 29, 2022

Accepted May 15, 2022

Keywords:

Frequency tunability

Gain

Isolation

Self-quadplexing antenna

Substrate integrated waveguide

ABSTRACT

This paper demonstrates a novel kind of cavity-backed self-quadplexing slot antenna for the S and C-band applications. The proposed antenna consists of 4 distinct “U”-shaped slots of different lengths and produces the quad frequency band for wireless communication systems. These slots are excited through the separate and orthogonal placed microstrip feed lines of 50 Ω ; generates four distinct operating bands at 3.2 GHz, 4.1 GHz, 5.8 GHz, and 7.2 GHz. Due to the perturbation of different U-shaped slots over the substrate integrated waveguide (SIW) cavity with defined positions, the high intrinsic port isolation value is better than 30.5 dB. Thus, the proposed unique antenna structure combines the four independent operating bands with minimum mutual coupling and negligible interference among input ports, which shows the self-quadplexing feature of the antenna. The proposed antenna also has the property of frequency tunability with unidirectional radiation pattern and gain of 5.8 dBi, 5.4 dBi, 4.01 dBi, and 3.47 dBi at corresponding operated frequency. The cross-polarization is 17.3 dB and the front-to-back ratio higher than 21.5 dB at all operating quad bands. There is a good agreement between simulated |S|-parameters results and equivalent circuit model results.

This is an open access article under the [CC BY-SA](https://creativecommons.org/licenses/by-sa/4.0/) license.



Corresponding Author:

Padmini Nigam

Department of Electronics and Communication Engineering, DIT University

Mussorie, Diversion Road, Dehradun 248009, India

Email: nigam242@gmail.com

1. INTRODUCTION

Nowadays, there is a rapid growth in compact devices and mobiles, which led to the rapid increase in the development of multi-band antennas. A multi-band antenna operates in a multi-band of frequencies. It remains active for one band, and the other part remains active for another band. By using a multi-band antenna, the overall cost and complexity of a multi-frequency wireless system are reduced. The conventional multi-band antennas have poor isolation among their ports. As a result, there is an undesired interference in the components connected to the ports. Further, a conventional multi-band antenna requires an external multiplexer circuit for independent transmission and reception. The external multiplexer also provides better isolation among the ports. However, the multiplexers increase the size and complexities [1]–[4].

In order to keep the compact size of the antenna, self-multiplexing antennas [5] such as self-diplexing [6]–[8] and self-triplexing [9], [10] are becoming the area of high interest. A self-multiplexing antenna does not need an external component for isolation. Self-diplexing antenna allows dual-band operations, i.e., they can be operated at two frequencies simultaneously. Similarly, the self-triplexing antenna enables triple-band operations, i.e., they can be performed at three frequencies at the same time. However, with the increase in the number of ports, there is a challenge to maintain isolation among the ports.

To meet future demands, there is a need for a self-quadplexing antenna. The self-quadplexing antenna can be operated on four different frequencies at the same time. The size of the self-quadplexing antenna is desired to be compact, and the port isolation should also be much improved. So the proposed antenna design has a compact size and better isolation levels at all resonating frequencies, which is the primary feature of the self-quadplexing antenna. The antenna works over four resonating frequencies at 3.2 GHz, 4.1 GHz, 5.8 GHz, and 7.2 GHz; this will cover the S (sub-6-GHz) and C-band applications like, worldwide interoperability for microwave access (WiMAX), wireless local area network (WLAN), mobile, and radar communication modules [11], [12].

2. ANTENNA CONFIGURATION AND WORKING PRINCIPLE

The geometrical structure of the proposed self-quadplexing antenna is shown in Figure 1 and dimensions are given in Table 1. The presented antenna has four “U”-shaped slots etched upon the substrate integrated waveguide (SIW) cavity and radiates over the four resonating frequencies at 3.2 GHz, 4.1 GHz, 5.8 GHz, and 7.2 GHz, respectively. Each “U” slot covers the quarter area of the SIW cavity; therefore, the SIW cavity is converted into the four quarter mode cavities approximately, and slots are etched in them individually. Each “U”-shaped slot is fed by the 50 Ω impedance microstrip feed line separately. The antenna is working on the principle of slot-loading effects [13], and the electromagnetic simulator tool high frequency structure simulator (HFSS) does its designing and analysis. However, the equivalent circuit model analysis is carried out with the help of the radio frequency (RF) component designing and analysis software named advanced design system (ADS). Here the dominating mode TE₁₁₀ and the length of the “U” slots are explained by (1) and (2), respectively [14], [15]. Dominant mode for the SIW cavity [14], [15],

$$f_{110,QM} = \frac{c}{\sqrt{2\pi\epsilon_r}} \sqrt{\left(\left(\frac{\pi}{L_{eff}}\right)^2 + \left(\frac{\pi}{W_{eff}}\right)^2\right)} \tag{1}$$

“U”-shaped slot length [15],

$$L_s = \frac{1}{2f_r\sqrt{\epsilon_r}} \tag{2}$$

L_{eff} and W_{eff} are the length and width of the SIW patch cavity, L_s is the “U”-shaped slot length corresponding to the resonating frequency f_r , and ϵ_r is the relative permittivity of the substrate reverse transcriptase (RT) Rogers/Duroid.

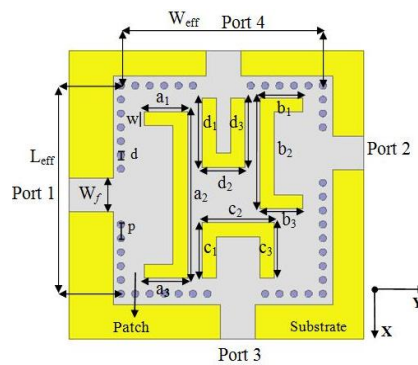

Figure 1. Geometry and top view of the proposed self-quadplexing antenna

$L_{eff} = 30.5$	$a_1 = 6.0$	$c_1 = 6.0$
$W_{eff} = 31.5$	$a_2 = 24$	$c_2 = 12.5$
$d = 1.0$	$a_3 = 6.0$	$c_3 = 6.0$
$p = 1.5$	$b_1 = 6.5$	$d_1 = 8.0$
$w = 2.0$	$b_2 = 17$	$d_2 = 4.0$
$W_f = 4.85$	$b_3 = 6.5$	$d_3 = 8.0$

2.1. Mode analysis in SIW cavity

The present antenna is based upon the trending and upcoming technology named SIW methodology combined with the four distinct feed lines of 50Ω impedance. Here, the mode analysis of the SIW cavity without any perturbation is carried out to define the proposed quad band antenna phenomenon. However, the SIW cavity mode as dominating (TE_{110}) and higher mode (TE_{120} , TE_{130} , and TE_{210}) is described by real $|Z|$ -parameters analysis as shown in Figure 2. When port 1 is ON, the first dominating mode TE_{110} is found at the 2.74GHz, and a higher mode (TE_{120}) is obtained at 6.24 GHz, as displayed in Figures 3(a) and 3(b). While when port 2 is ON, the dominating mode is defined at 3.26 GHz, and high order mode (TE_{130}) is obtained at 6.82 GHz, shown in Figure 2 and Figure 3(c), respectively. Similarly, when port 3 and port 4 is ON simultaneously, the dominating mode is obtained at 4.33 GHz and 5.26 GHz correspondingly. In contrast, the higher mode (TE_{210} , TE_{310}) is found at 7.53 GHz and 8.73 GHz, respectively, as presented in Figures 3(d) and 3(e). This is verified by the $|Z|$ - parameters and magnetic field distribution of corresponding modes into the SIW cavity.

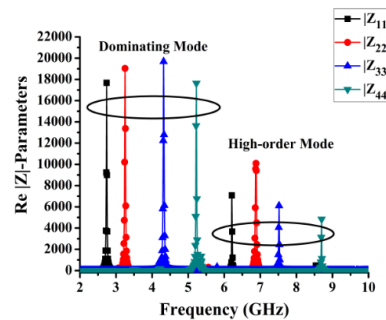

Figure 2. $|Z|$ -parameters of the proposed SIW cavity

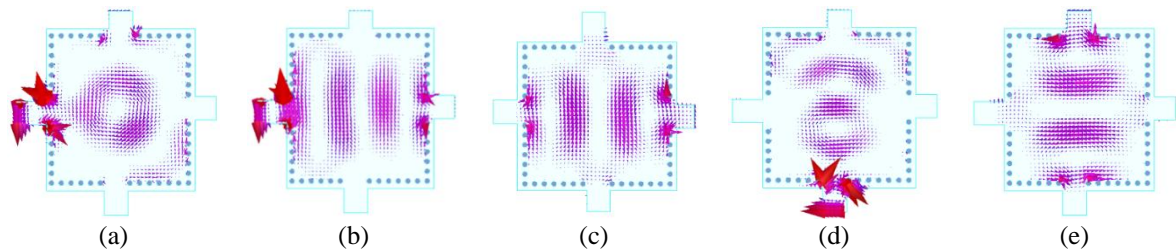

Figure 3. Magnetic field distribution (H-field) in SIW cavity (a) dominant mode (TE_{110}), (b) TE_{120} when port 1 is ON, (c) TE_{130} when port 2 is ON, (d) TE_{210} when port 3 is ON, (e) TE_{310} when port 4 is ON

3. THE PROPOSED SELF-QUADPLEXING ANTENNA

The proposed self-quadplexing antenna is composed of four distinct “U”-shaped slots of different lengths etched over the SIW patch cavity. Each “U”-shaped slot has the quarter size of the overall SIW cavity. The SIW cavity has an area of 960.75 mm^2 (30.5×31.5), and each quarter cavity has an area of 240 mm^2 approximately [16], [17]. Here the each “U” slot is facing their identical ports. The “U” slot 1 and 2 is orthogonal to port 1 and port 2, while slot 3 is inverted to port 3, and slot 4 is in a linear fashion to port 4.

The proposed antenna is working over the principle of the slot-loading effect and higher mode perturbation technique. Previously, the without etched any slots, i.e., SIW cavity has the various higher modes accordingly to which port is ON. In the SIW cavity, port 1 is ON; the higher mode (TE_{120} mode) is placed at 6.24 GHz. Similarly, when port 2 and port 3 is ON simultaneously, the high order mode (TE_{130} , TE_{210}) is defined at 6.82 GHz and 7.53 GHz, respectively. Likewise, when port 4 is ON, the higher mode TE_{310} found at 8.73 GHz, as shown in Figure 2 and Figure 3 correspondingly.

After perturbations of the four different “U”-shaped slots over the SIW cavity, the higher modes converted into the four distinct resonating frequency bands simultaneously. When the “U” slot-1 is etched upon the SIW cavity, due to the longer “U”-shaped arm, the higher mode TE_{120} at 6.24 GHz gets perturbed into the first resonant frequency at 3.2 GHz as displayed in Figure 4(a). The length of slot-1 is greater than other slots, so the slot-loading effect is much higher than others, and the difference between the frequencies

of the higher mode and the 1st resonating mode is also high [18]. Similarly, when port 2 is ON and slot 2 is etched over the SIW cavity, the higher mode TE₁₃₀ at 6.82 GHz turns into the 2nd resonating frequency of 4.1 GHz due to the slot 2 loading effect as shown in Figure 4(b). Likewise, when port 3 and port 4 is ON simultaneously and slot 3 and slot 4 are etched over the SIW cavity, the corresponding higher mode TE₂₁₀, TE₃₁₀ mode gets perturbed into 3rd and 4th resonating frequency at 5.8 GHz and 7.2 GHz, respectively, as presented in Figures 4(c) and 4(d). Therefore, the working of the proposed antenna entirely depends upon the higher mode and the slot-loading effect.

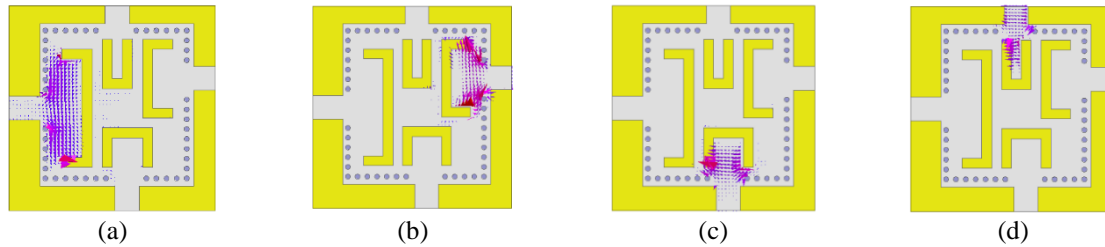

Figure 4. Resonating pattern (Magnetic field distribution) with “U”-shaped slot (a) port 1 ON, (b) port 2 ON, (c) port 3 ON, and (d) port 4 ON

4. EXPERIMENTAL RESULTS VALIDATION

The presented SIW based cavity-backed self-quadplexing slot antenna is experimentally simulated using the substrate Rogers RT/Duroid 5880 with permittivity (ϵ_r) of 2.2 and the thickness (t) of 1.575 mm. The simulated |S|-parameters (reflection coefficients and isolation) among all input ports are shown in Figure 5. The measured results can be obtained by ON the particular port, and the other unused ports are terminated by the matched load of 50 Ω . The proposed antenna is a narrower band antenna with a simulated impedance bandwidth of 110 MHz, 90 MHz, 100 MHz, and 70 MHz at four operating frequencies. The antenna’s simulated gain and radiation efficiency is shown in Figures 6. From Figures 6(a) and 6(b), the gain and antenna efficiency have an inverse relation with the frequency band. The gain is 5.8 dBi, 5.4 dBi, 4.01 dBi, and 3.47 dBi respectively and efficiency is better than 74% at all resonating frequency.

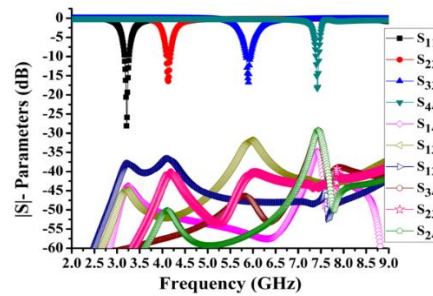

Figure 5. The simulated values of |S|-parameters of the proposed antenna by HFSS simulator

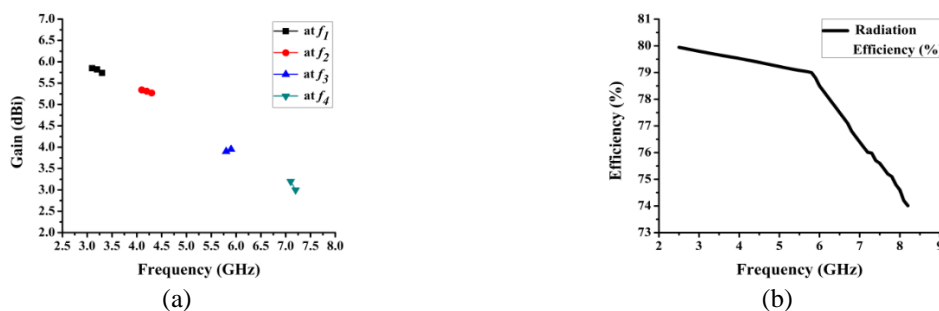

Figure 6. The simulated value of; (a) gain and (b) radiation efficiency of the proposed antenna

The presented antenna has the uni-directional radiation pattern, i.e., linear polarization of the “U”-shaped slot radiator as displayed in Figures 7(a)-(d). At a time, single port works, and the unused ports are matched with the 50Ω load simultaneously. Here the simulated cross-polarization values are 30.2 dB, 28.6 dB, 17.3 dB, and 20.6 dB corresponding to all resonating frequency. The FTBR values are 21.5 dB, 23.3 dB, 27.8 dB, and 28.2 dB respectively. The characteristic of the present quad-band antenna is defined in tabular format as in Table 2.

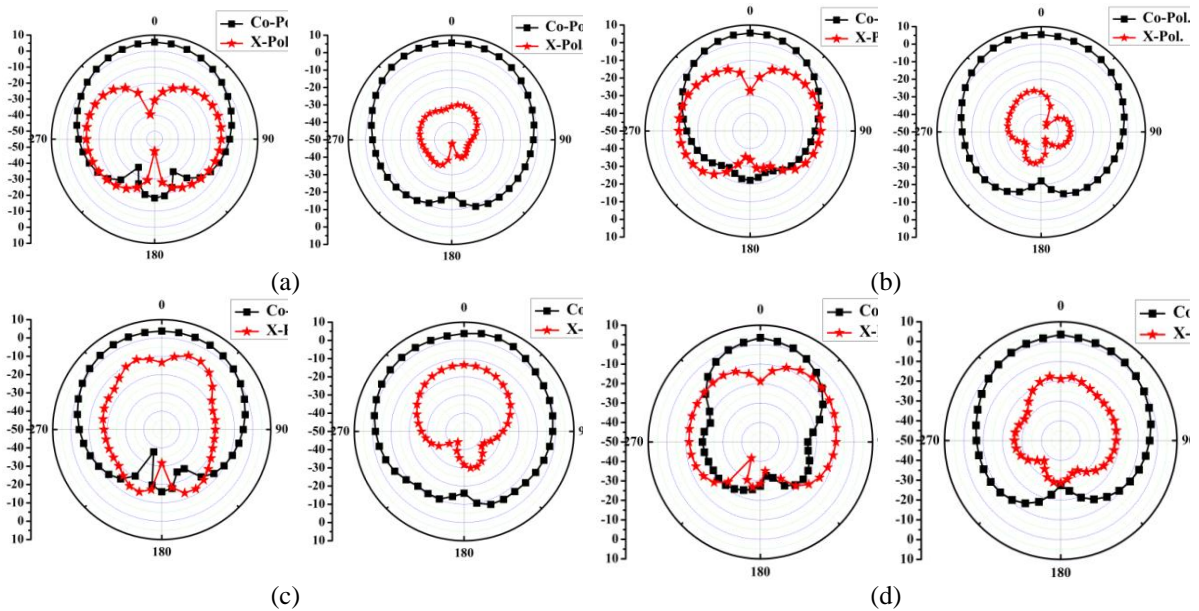

Figure 7. The simulated value of radiation parameters at $\phi=0^\circ$, $\phi=90^\circ$ of the proposed antenna, when (a) port 1 ON, (b) port 2 ON, (c) port 3 ON, and (d) port 4 ON

Table 2. The proposed antenna characteristics

Port excitation	Minimum isolation (dB)	Cross-Pol. (dB)	Gain (dBi)	-10dB Bandwidth (MHz)	Front to back ratio (dB)
Port 1	37.2	30.2	5.8	110	21.5
Port 2	36.8	28.6	5.4	90	23.3
Port 3	32.6	17.3	4.01	100	27.8
Port 4	30.4	20.6	3.47	70	28.2

4.1. Equivalent circuit model analysis

For the validation of simulated $|S|$ -parameters of the proposed self-quadplexing slot antenna, the analysis of the equivalent circuit model is displayed in Figure 8. The present antenna is composed of 4 distinct “U”-shaped slots of different lengths and provides the four specific operating frequency bands. The proposed equivalent circuit model is simulated by the advanced design simulator (ADS) software, generally used for the lumped circuit simulations. Here, each “U”-shaped slot is illustrated by the individual parallel radio link control (RLC) network, as the 1st RLC network produces the 1st deep resonance at 3.25 GHz; similarly, the 2nd RLC network has the 2nd resonance at 4.21 GHz. Likewise, the 3rd and 4th RLC section defines the resonating notch at 5.86 GHz and 7.24 GHz, respectively. All the notched resonances values are greater than -10 dB with the narrower impedance bandwidth (MHz). These parallel RLC sections are connected with the individual input ports, and the mutual coupling among the ports has interpreted the series link control (LC) network separately [19]. Here the mutual coupling or interferences are explained by series LC sections between any of two input ports. Here M_{14} defines the mutual coupling between port 1 and port 4. Likewise, five others more LC sections are displayed in Figure 8 as M_{13} , M_{12} , M_{23} , M_{24} , and M_{34} .

Similarly, M_{13} defines the mutual coupling between port 1 and port 3 and vice versa. Here the minimum isolation of 30.48 dB is obtained among the input ports, as shown in Figure 9. The values of all the lumped elements as parallel RLC and series LC sections [20], [21] are given in Table 3. The equivalent circuit model is used to justify the simulated $|S|$ -parameters results of the HFSS simulator; however, both $|S|$ -

parameters (resonance and mutual coupling) define the closed agreement between the electromagnetic (EM) simulator (HFSS) and equivalent model (ADS) based results.

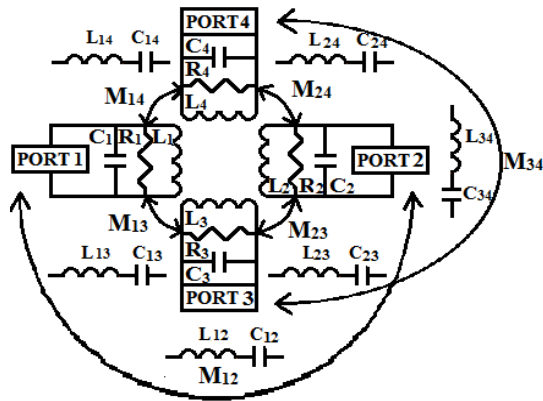

Figure 8. The equivalent circuit model of the proposed self-quadplexing slot antenna

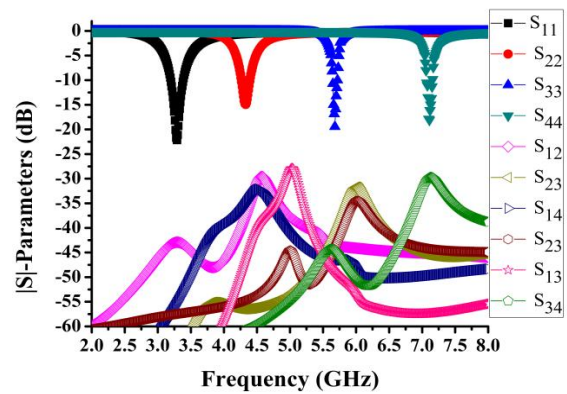

Figure 9. The simulated value of |S|-parameters of the proposed antenna by ADS software

Table 3. RLC and Mutual coupling values of the equivalent circuit model of the proposed antenna. [R in KΩ, L in nH, C in pF]

R ₁ = 0.42	R ₃ = 0.39	L ₁₂ =8.97	L ₂₃ =6.46
L ₁ = 1.97	L ₃ =0.00448	C ₁₂ =1.96	C ₂₃ =2.78
C ₁ = 1.284	C ₃ =1.68	L ₁₃ =7.54	L ₂₄ =5.78
R ₂ = 0.57	R ₄ = 0.324	C ₁₃ =1.74	C ₂₄ =2.93
L ₂ = 1.033	L ₄ =0.00267	L ₁₄ =7.32	L ₃₄ =6.78
C ₂ = 1.46	C ₄ =1.83	C ₁₄ =2.52	C ₃₄ =3.04

The antenna has adequate isolation of better than 30.5dB among ports with reasonable characteristics as the higher front-to-back ratio (FTBR) and smaller electrical size than others [13], [22], as displayed in Table 4 also. As in [23] and [22] are required extra quadplexer device to maintain reasonable isolation among the input ports. The present antenna is a multi-port multi-band device with better radiation efficiency and uni-directional radiation patterns. At the same time, [23] and [22] are the multi-band single port element and give bidirectional radiation mechanisms.

Table 4. Comparison among multiplexer and self-quadplexing circuit modules

Features/ Ref.	Proposed Work	[24]	[23]	[22]	[25]	[26]
Resonating Frequencies (GHz)	3.2, 4.1, 5.8, 7.2	3.5, 5.2, 5.5, 5.8	8.1, 8.78, 9.7, 11.0	5.14, 5.78, 6.74, 7.74	2.4, 3.5, 5.2, 5.8	1.2, 2.4, 3.5, 5.2
Min. Isolation	30.5	23.6	22.6	28	NA	NA
Permittivity (ε _r)	2.2	2.2	2.2	2.33	NA	NA (μ _r = 1)
Gain (dBi)	5.8, 5.3, 3.9, 3.4	5.43, 4.1, 3.56, 3.6	5.5, 6.9, 7.47, 7.45	4.1, 4.96, 6.2, 6.1	2.8, 2.1, 3.5, 3.2	5.47, 5.88, 1.97, 3.56
Frequency tunability	Yes	Yes	Yes	Yes	No	No
Size (mm ²)	30.5×31.5	38.8×25.6	29×29	22×22	25×20	90×60
FTBR (dB)	>21.5	NA	>17	>17.5	NA	NA
Multiplexing circuit	Not required	Not required	Not required	Not required	Required	Required

*FTBR- Front to back ratio

**N.A. (not available)

5. CONCLUSION

The proposed paper elaborates a cavity-backed self-quadplexing antenna for four bands application; that includes the operation of sub 6 GHz (WiMAX (3.2 GHz and 4.1 GHz), and WLAN (5.8 GHz)), and C-band (7.2 GHz). The position of bands can be managed by the individual “U”-shaped slot accordingly to the requirement; i.e., the antenna has the property of frequency tunability. The proposed antenna can be used for the sub-6-GHz (WiMAX and WLAN), radar, and space research applications.



ACKNOWLEDGEMENTS

The authors would like to thank the DIT University, Dehradun, for providing the HFSS software for the simulation of RF components and antenna designs.



REFERENCES

- [1] W. C. Mok, S. H. Wong, K. M. Luk, and K. F. Lee, "Single-layer single-patch dual-band and triple-band patch antennas," *IEEE Transactions on Antennas and Propagation*, vol. 61, no. 8, pp. 4341–4344, Aug. 2013, doi: 10.1109/TAP.2013.2260516.
- [2] C.-K. Hsu and S.-J. Chung, "Compact antenna with U-shaped open-end slot structure for multi-band handset applications," *IEEE Transactions on Antennas and Propagation*, vol. 62, no. 2, pp. 929–932, Feb. 2014, doi: 10.1109/TAP.2013.2289996.
- [3] Y. Xie, F. C. Chen, and J. F. Qian, "Design of integrated duplexing and multi-band filtering slot antennas," *IEEE Access*, vol. 8, pp. 126119–126126, 2020, doi: 10.1109/ACCESS.2020.3006831.
- [4] S. Agrawal, M. S. Parihar, and P. N. Kondekar, "A quad-band antenna for multi-band radio frequency energy harvesting circuit," *AEU - International Journal of Electronics and Communications*, vol. 85, pp. 99–107, Feb. 2018, doi: 10.1016/j.aeue.2017.12.035.
- [5] S. Sharma, P. Nigam, A. Muduli, and A. Pal, "Highly isolated self-multiplexing 5G antenna for IoT applications," in *Blockchain for 5G-Enabled IoT*, Cham: Springer International Publishing, 2021, pp. 593–619.
- [6] P. Nigam, A. Muduli, S. Sharma, and A. Pal, "The substrate integrated waveguide-based dumbbell-shaped self-diplexing cross-slot antenna," in *Lecture Notes in Mechanical Engineering*, 2021, pp. 523–534.
- [7] P. Nigam, A. Muduli, S. Sharma, and A. Pal, "SIW based self-diplexing dumbbell slot antenna for X-band application," in *Proceedings - 2019 Women Institute of Technology Conference on Electrical and Computer Engineering, WITCON ECE 2019*, Nov. 2019, pp. 231–234, doi: 10.1109/WITCONECE48374.2019.9092900.
- [8] P. Nigam, A. Muduli, S. Sharma, and A. Pal, "SIW based dual fed cavity-backed self-diplexing slot antenna," *Telecommunications and Radio Engineering*, vol. 79, no. 16, pp. 1455–1466, 2020, doi: 10.1615/TelecomRadEng.v79.i16.40.
- [9] P. Nigam, A. Muduli, S. Sharma, and A. Pal, "The substrate integrated waveguide based self-triplexing cross slot antenna," in *2019 Women Institute of Technology Conference on Electrical and Computer Engineering (WITCON ECE)*, Nov. 2019, pp. 241–246, doi: 10.1109/WITCONECE48374.2019.9092932.
- [10] P. Nigam, R. Agarwal, A. Muduli, S. Sharma, and A. Pal, "Substrate integrated waveguide based cavity-backed self-triplexing slot antenna for X-Ku band applications," *International Journal of RF and Microwave Computer-Aided Engineering*, vol. 30, no. 4, p. e22172, Apr. 2020, doi: 10.1002/mmce.22172.
- [11] H. Chen, X. Yang, Y. Z. Yin, S. T. Fan, and J. J. Wu, "Triband planar monopole antenna with compact radiator for WLAN/WiMAX applications," *IEEE Antennas and Wireless Propagation Letters*, vol. 12, pp. 1440–1443, 2013, doi: 10.1109/LAWP.2013.2287312.
- [12] H. Zhai, Z. Ma, Y. Han, and C. Liang, "A compact printed antenna for triple-band WLAN/WiMAX applications," *IEEE Antennas and Wireless Propagation Letters*, vol. 12, pp. 65–68, 2013, doi: 10.1109/LAWP.2013.2238881.
- [13] K. Hong, X. Zhang, L. Zhu, X. Bi, and T. Yuan, "Slot loading effect on impedance and radiation performance of high-gain patch antenna under TM 03 -mode operation," *International Journal of RF and Microwave Computer-Aided Engineering*, vol. 29, no. 12, p. e21967, Dec. 2019, doi: 10.1002/mmce.21967.
- [14] A. Singh, K. Kamakshi, M. Aneesh, and J. A. Ansari, "Slots and Notches Loaded Microstrip Patch Antenna for Wireless Communication," *TELKOMNIKA Indonesian Journal of Electrical Engineering*, vol. 13, no. 3, p. 909, Mar. 2015, doi: 10.11591/telkomnika.v13i3.7282.
- [15] T. Zhang, W. Hong, Y. Zhang, and K. Wu, "Design and analysis of SIW cavity backed dual-band antennas with a dual-mode triangular-ring slot," *IEEE Transactions on Antennas and Propagation*, vol. 62, no. 10, pp. 5007–5016, Oct. 2014, doi: 10.1109/TAP.2014.2345581.
- [16] T. Deckmyn *et al.*, "A novel 60 GHz wideband coupled half-mode/quarter-mode substrate integrated waveguide antenna," *IEEE Transactions on Antennas and Propagation*, vol. 65, no. 12, pp. 6915–6926, Dec. 2017, doi: 10.1109/TAP.2017.2760360.
- [17] Y.-X. Sun, D. Wu, X. S. Fang, and N. Yang, "Compact quarter-mode substrate-integrated waveguide dual-frequency millimeter-wave antenna array for 5G applications," *IEEE Antennas and Wireless Propagation Letters*, vol. 19, no. 8, pp. 1405–1409, Aug. 2020, doi: 10.1109/LAWP.2020.3003305.
- [18] M. Khan and D. Chatterjee, "Analysis of reactive loading in a U-slot microstrip patch using the theory of characteristic modes [antenna applications corner]," *IEEE Antennas and Propagation Magazine*, vol. 60, no. 6, pp. 88–97, Dec. 2018, doi: 10.1109/MAP.2018.2870653.
- [19] K. J. Coakley, J. D. Splett, M. D. Janezic, and R. F. Kaiser, "Estimation of Q-factors and resonant frequencies," *IEEE Transactions on Microwave Theory and Techniques*, vol. 51, no. 3, pp. 862–868, Mar. 2003, doi: 10.1109/TMTT.2003.808578.
- [20] R. Gomez-Garcia, L. Yang, J.-M. Munoz-Ferreras, and Di. Psychogiou, "Single/multi-band coupled-multi-line filtering section and its application to RF diplexers, bandpass/bandstop filters, and filtering couplers," *IEEE Transactions on Microwave Theory and Techniques*, vol. 67, no. 10, pp. 3959–3972, Oct. 2019, doi: 10.1109/TMTT.2019.2933212.
- [21] N. S. Luhrs, D. J. Simpson, and D. Psychogiou, "Multiband acoustic-wave-lumped-element resonator-based bandpass-to-bandstop filters," *IEEE Microwave and Wireless Components Letters*, vol. 29, no. 4, pp. 261–263, Apr. 2019, doi: 10.1109/LMWC.2019.2901199.
- [22] S. K. K. Dash, Q. S. Cheng, and R. K. Barik, "A compact substrate integrated waveguide backed self-quadruplexing antenna for C-band communication," *International Journal of RF and Microwave Computer-Aided Engineering*, vol. 30, no. 10, p. e22366, Oct. 2020, doi: 10.1002/mmce.22366.
- [23] S. Priya, S. Dwari, K. Kumar, and M. K. Mandal, "Compact Self-Quadruplexing SIW Cavity-Backed Slot Antenna," *IEEE Transactions on Antennas and Propagation*, vol. 67, no. 10, pp. 6656–6660, Oct. 2019, doi: 10.1109/TAP.2019.2925124.
- [24] A. Kumar, "Design of self-quadruplexing antenna using substrate-integrated waveguide technique," *Microwave and Optical Technology Letters*, vol. 61, no. 12, pp. 2687–2689, Dec. 2019, doi: 10.1002/mop.31952.
- [25] X. Sun, G. Zeng, H.-C. Yang, and Y. Li, "A compact quadband CPW-fed slot antenna for M-WiMAX/WLAN applications," *IEEE Antennas and Wireless Propagation Letters*, vol. 11, pp. 395–398, 2012.
- [26] Haiwen Liu, Pin Wen, Shuangshuang Zhu, Baoping Ren, Xuehui Guan, and Hui Yu, "Quad-band CPW-Fed monopole antenna based on flexible pentangle-loop radiator," *IEEE Antennas and Wireless Propagation Letters*, vol. 14, pp. 1373–1376, 2015, doi: 10.1109/LAWP.2015.2406391.



BIOGRAPHIES OF AUTHORS

Ms. Padmini Nigam    received her B.Tech (Electronic & Communication) & M. Tech (Microwave Engineering) degree from UPTU, Lucknow. Currently, she is a research fellow at DIT, University, Dehradun. Her research interest includes- substrate integrated waveguide-based antennas, self-diplexing/ self-triplexing antenna & filters. She has published various conference and journal papers and attended workshops on antenna designs also. She can be contacted at email: nigam242@gmail.com.





Dr. Arjuna Muduli    is working as an Associate Professor in the Department of Electronics and Communication Engineering at K L E F (Deemed to be University), Vijayawada, India. He has received his Ph.D. degree from Berhampur University, Odisha. His research interest includes RF and Antenna, Wireless communication; Software-defined radio, and Cognitive Radio. He can be contacted at email: arjunamuduli@gmail.com.



Dr. Sandeep Sharma    received his B.Sc. degree in Electronics from government science college Gwalior and M.Sc. Degree in Electronics from the department of Electronic Sciences University of Delhi South Campus, Delhi, India. He later received his Ph.D. degree from the Department of Electronics Sciences, University of Delhi South campus, Delhi, India. He has published several National and International Journals, including many SCI Journals. He can be contacted at email: tek.learn@gmail.com.



Dr. Amrindra Pal    received a master's degree in Electrical and Instrumentation Engineering from the Thapar University, Patiala. He is completed his Ph.D. degree from the Department of Electronics and Communication Engineering, DIT University, Dehradun. He is working in the area of designing and modeling electro-optic devices. He has published several SCI papers in reputed journals. He can be contacted at email: amrindra.pal123@gmail.com.