

Designing the operation monitor of battery of the generator in the base transceiver station

Nguyen Thi Xoan, Tran Văn Bình, Hà Ngọc Thuan, Bạch Van Nam

Faculty of Electronic Engineering, Thai Nguyen University of Technology, Thái Nguyên, Vietnam

Article Info

Article history:

Received Apr 18, 2021

Revised May 10, 2022

Accepted Jun 5, 2022

Keywords:

Base transceiver station

Battery

Battery monitoring in base transceiver station

ABSTRACT

The base transceiver station (BTS)'s continuous power supply has been the subject of a lot of research. The majority of research focuses on increasing power usage effectiveness or adding solar battery systems for BTS stations. Due to the geographical conditions in the North of Vietnam, solar cell efficiency is rather poor and the investment cost is quite high, therefore BTS stations are still relying mostly on battery and generator backup systems. This article presents a design solution to designing the operation monitor of battery of the generator in the base transceiver station. From solution design, the authors designed the hardware and software. The device allows communication and sends alarms to the base transceiver station (BTS) manager. Through the testing process, the system has met the requirements of the problem and is easily integrated into the BTS.

This is an open access article under the [CC BY-SA](#) license.



Corresponding Author:

Bach Van Nam

Faculty of Electronic Engineering, Thai Nguyen University of Technology

Số 666 Đ. 3/2, P, Thành phố Thái Nguyên, Vietnam

Email: bachvannam@tnut.edu.vn

1. INTRODUCTION

In our daily life, the communication of information is very important and indispensable. It determines the activities of many fields of the society, it helps people to get much valuable information about culture, science, technology, and education in the quickest way. Today, with the increasing demand for information from humans, it is required that service providers have modern facilities to meet the needs of customers "anytime, anywhere". Today's telecommunications system is no longer too unfamiliar to Vietnamese people, especially mobile communication system is very popular, no longer only for high-income people like before, but is gradually becoming services for everyone.

In the telecommunications system, transmission is a very important role, can be said to be the foundation for the whole system. Currently, the mobile communication network is used on global system for mobile communications (GSM) technology. Mobile phone subscribers can connect to GSM network through the base transceiver station (BTS). In a BTS station, in addition to the transceiver (antenna, fiber tube, fiber optic cable, and signal processing cabinet), there are other auxiliary components (such as: air conditioner, fan, electric bulb, automatic transfer switch cabinet (ATS)). And an indispensable component to maintaining continuous information is the power supply system, including power source, battery, and generator. In the event of power outage, the battery system will be connected. When the battery voltage is the specified level (about 48V), the generator must be switched on immediately.

There is a lot of research that has been focusing on the continuous power supply of the base transceiver station (BTS). Researches mainly focus on improving the efficiency of using electricity [1], [2] or researches that focus on installing solar battery systems for BTS station [3]–[5]. However, with the geographical features in the North of Vietnam, the efficiency of using solar cells is quite low and the

investment cost is quite high, so now BTS stations are still using the main backup source, which is battery and generator.

Because the BTS station is an independent entity, often located on high hills, and large areas, generator maintenance cannot be done regularly. So, there are times when the power is out, so the generator must be started but it doesn't work. One of the reasons for a generator not working is the fault of the generator battery. In the event of power outage, the backup battery has been exhausted, however, the generator (integrated ATS) is not working and contact is lost. However, no researches have focused on remote monitoring and warning of the status of generator battery in BTS stations. Architecture of BTS supply as shown in Figure 1. In this article, we propose a design solution for generator battery operation monitoring in the BTS station. The article is divided into 5 parts: Introduction, design solution, designing hardware and software, experiments, and results conclusion.

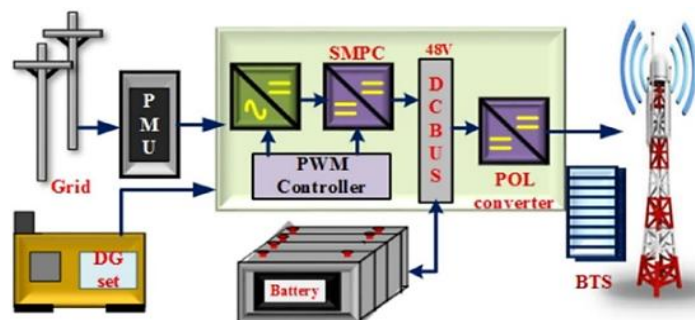

Figure 1. The architecture of the usual supply for BTS [1]

2. DESIGN SOLUTION

As introduced in part one, the cause of a generator not working during a power outage is a fault of the generator battery. The batteries used to start the generator are usually 12V DC batteries. Several methods for determining generator battery fault are given in [6]–[8]. Methods of determination include: visual inspection and check charging status (specific gravity, open-circuit voltage measurement, capacity or heavy load test).

In our research, the team plans to design a circuit that quickly determines the status of the battery and sends monitoring and warning information to the station manager. The visual determination method (visually checking if the battery is blistering) cannot be used since we use remote monitoring. The method of testing capacity or load requires specialized machines, so the cost is very high, if each station equips one machine, the total cost will be very large. For the purpose of designing the monitoring set of generator battery in BTS stations which is a simple set, reasonable price. The team used open-circuit voltage measurement to determine the battery's status.

To determine the working condition of the battery through open-circuit voltage measurement [8] we perform the steps:

- Use a digital voltmeter to check the open-circuit voltage of the battery. Analog gauges are inaccurate and should not be used.
- Disconnect the battery from the load, switch the meter to V-DC measurement mode, properly connect the digital meter poles to the battery terminals and measure.
- Reading the index meter to determine the status of the battery.

Table 1 shows Acquy's state of charge (SoC) estimates started with the battery council international (BCI) standard [9]. A fully charged battery will have an open-circuit voltage of 12.6V. On the other hand, a completely dead battery will have an open-circuit voltage of less than 12.0V.

From the studies, the authors give the following procedure to design a generator battery monitor in BTS stations:

- Design voltage measurement instead of using digital meters.
- Design the switch to open the battery circuit to the load when performing the measurement.
- Every 30 days, measuring the battery's open-circuit voltage to determine the status of the battery and send an alert to the BTS station manager.

- During the periodic inspection, if the generator is working, the test should not be carried out. So as not to affect the working process of the generator, so on the circuit, it must be determined the working condition of the machine.
- The power source for the circuit is independent, does not use the voltage of the generator's battery.

Table 1. BCI standard table for estimating the SoC of starter batteries

Approximate state-of-charge	Average specific gravity	Open circuit voltage				
		2V	6V	8V	12V	2V
100%	1.265	2.10	6.32	8.43	12.65	100%
75%	1.225	2.08	6.22	8.30	12.45	75%
50%	1.190	2.04	6.12	8.16	12.24	50%
25%	1.155	2.01	6.03	8.04	12.06	25%
0%	1.120	1.98	5.95	7.72	11.89	0%

2.1. Block diagram of generator battery operation monitor in the BTS station

From the design solution to the problem, we build the block diagram of the generator battery operation monitor in the BTS station as shown in Figure 2. Regarding to Figure 2, the function of blocks can be explained: i) Central controller: Arduino Nano is used to process input information and send signals to the switching block, warning card and voltage display block; ii) Vibration sensor: Determine if the generator is working; iii) Measurement circuit: Used to measure the voltage on the battery; iv) Real-time module: Determine the time of checking battery status; v) Voltage display block: Display the measured voltage value; vi) Warning card: The fault warning signal battery will be sent to the warning card (has been integrated into the ATS cabinet or an external alarm) and send a warning to the manager; vii) Switching: Used to disconnect the load from the battery in open-circuit voltage measurement mode.

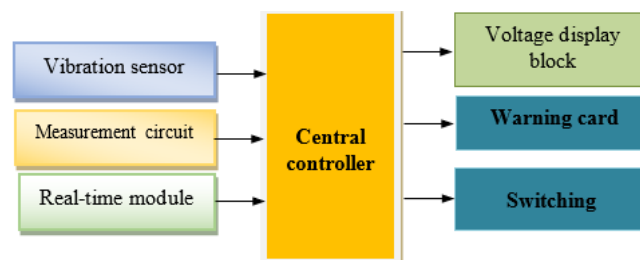

Figure 2. The diagram of equipment

3. DESIGNING SOFTWARE AND HARDWARE

3.1. Designing hardware

The generator battery operation monitor in the BTS station consists of six main parts: i) The central microcontroller using the Arduino Nano board, ii) Circuit to detect vibration sensor circuit, iii) Voltage measurement circuit, iv) Display circuit, v) Real-time block and vi) Switching block.

3.1.1. The central microcontroller

The Arduino Nano board is one of the smallest versions of the Arduino board. Arduino Nano has all the functions and programs available on Arduino Uno due to the same use of microcontroller (MCU) ATmega328P [10]. Thanks to the use of the paste IC of the ATmega328P instead of the plug IC, so the Arduino Nano has more than the Arduino Uno 2 pins Analog. Arduino Nano is connected to the computer via mini universal serial bus (USB) port and uses CH340 chip to convert USB to universal asynchronous receiver and transmitter (UART) instead of using ATmega16U2 chip to emulate communication (COM) port like Arduino Uno or Arduino Mega, so the product cost is reduced. The Arduino Nano board is shown in Figure 3 and the technical data sheet of Arduino Nano as shown in Table 2.

3.1.2. Designing a circuit to detect vibration sensor circuit

The vibration sensor (P4) is the (HDX)-1801 type of vibration sensor that works as a switch when vibration is received. The vibration sensor circuit as shown in Figure 4. When the generator is not working, the vibration sensor (P4) does not sense the vibration, input pin 2 of the IC LM741 is low, the case based

reasoning (CBR) output signal is low. When the generator is working, the vibration sensor (P4) senses the vibration, the input pin 2 of the IC LM741 is high, the CBR output signal is high. The output signal from the vibration sensor CBR circuit is fed to the input of the Arduino Nano board.

Table 2. Technical data sheet of Arduino Nano

Technical specifications	
Microcontroller	Atmel ATmega328
Operating voltage (logic level)	5 V
Input voltage (recommended)	7-12 V
Digital I/O Pins	14 (of which 6 provide PWM output)
Analog input pins	8
DC current per I/O Pin	40 mA
Flash memory	32 KB (ATmega328) of which 2 KB used by bootloader
SRAM	2 KB (ATmega328)
EEPROM	1 KB (ATmega328)
Clock speed	16 MHz
Dimensions	0.73"×1.70"

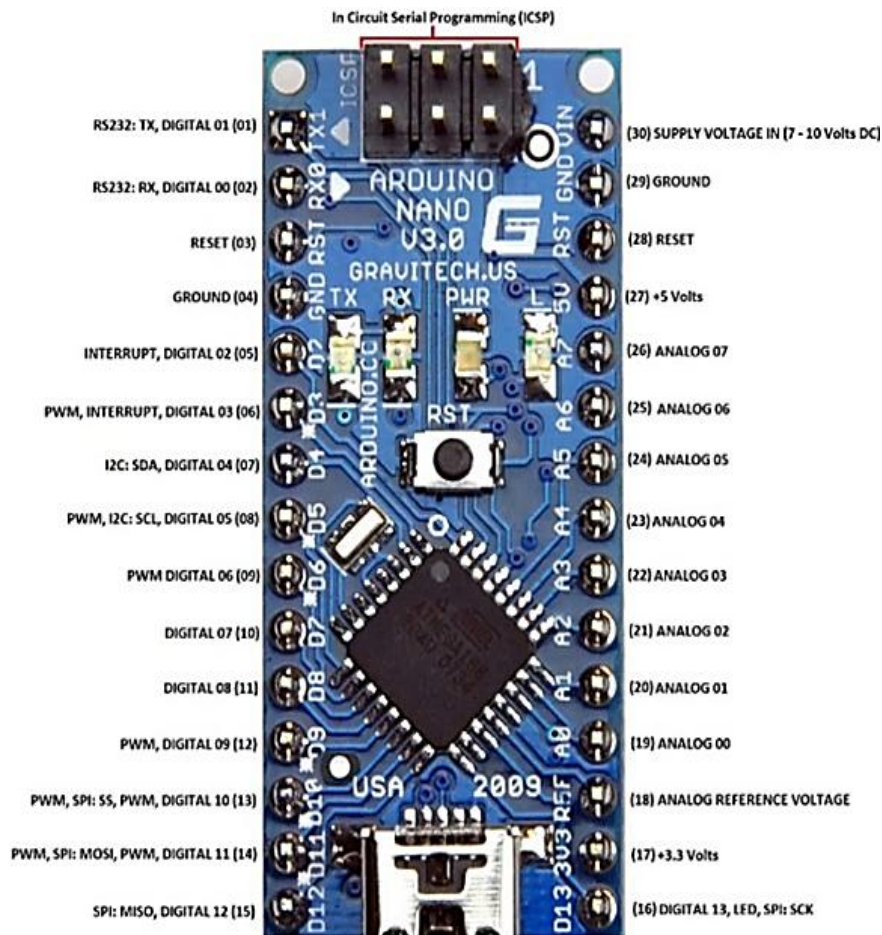

Figure 3. Arduino Nano board image

3.1.3. Voltage measurement circuit

To determine the voltage between the two battery electrodes (V^+ and V^-), a voltage divider circuit consisting of two resistors R_2 and R_3 is connected between the two electrodes. The voltage V_{in} measured from the bias circuit will be calculated by (1).

$$V_{in} = \frac{R_3}{R_2 + R_3} V + \quad (1)$$

With the value of voltage across 2 electrodes of battery are: $V_- = 0V$, $V_{max+} = 15V$, $V_{in} = 0V \div 5V$, we select: $R_3 = 5k\Omega$, $R_2 = 10k\Omega$ to ensure the exact measurement results.

In order to Arduino to read V_{in+} , we have to use an analog-to-digital converter analog-to-digital converter (ADC), Arduino Nano has a 10-bit ADC converter corresponding to 1024 levels. The resolution of the ADC is (2).

$$\text{Resolution} = \frac{V_{ref+} - V_{ref-}}{1024 - 1} \tag{2}$$

Arduino Nano has $V_{ref+} = 5V$ and $V_{ref-} = 0V$, so resolution is (3).

$$\text{Resolution} = \frac{5 - 0}{1024 - 1} = 4,8876mV \tag{3}$$

It means for every analog signal of 4.87mV, ADC value increments by one. The circuit diagram of voltage measurement circuit can be seen in Figure 5.

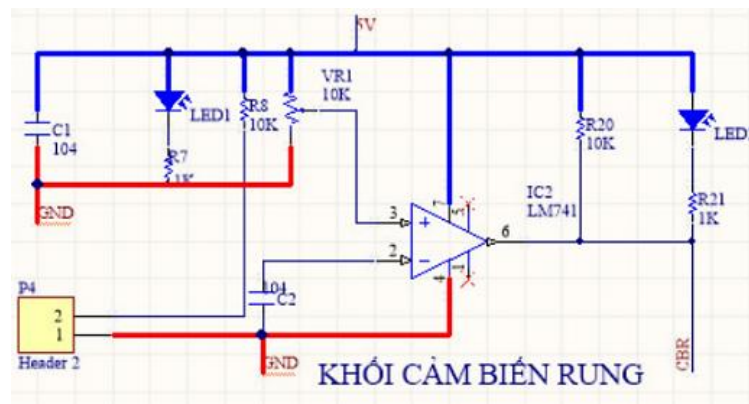

Figure 4. Vibration sensor circuit

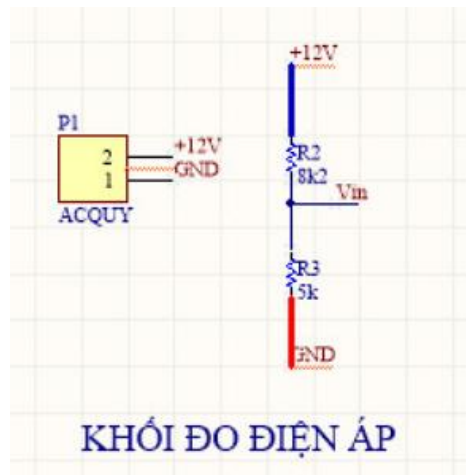

Figure 5. Circuit diagram of voltage measurement circuit

3.1.4. Voltage display circuit

Battery voltage value will be displayed on 4 seven-segment display type common cathode and use IC 4511 to decode signals from Arduino. The diagram of the voltage display circuit as shown in Figure 6.

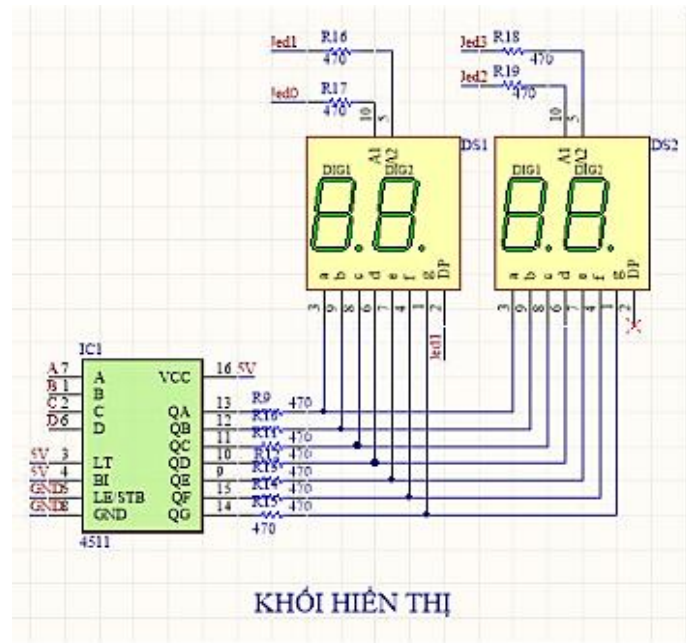

Figure 6. The diagram of the voltage display circuit

3.1.5. Real-time block

The DS1302 module uses the DS1302 IC clock chip [10], consisting of a real-time clock / calendar and 31 bytes of static RAM, communicating via a simple serial interface to the microcontroller. Real-time clock/calendar circuit providing seconds, minutes, hours, day, week, month, year and information, number of days per month and date jump can be automatically adjusted. Clock operation can be set to 24 or 12-hour AM/PM format. Common chips can be used to receive and process data such as 8051, AVR, PIC, Arduino. Real-time block can be seen in Figure 7.



Figure 7. Real-time block

3.1.6. Switching block

When the circuit is not in voltage measurement mode, the central control supplies logic level "1" to the Vmo pin, leading to transistor Q1 open, relay suck contact, maintaining closed circuit between generator's battery and generator. When the circuit switches to the battery's open-circuit voltage measurement mode (according to the preset schedule), the central controller supplies logic level "0" to the Vmo pin, which leads to transistor Q1 locked, Relay release contact, open circuit between the generator's battery and the generator, then the voltage measuring circuit takes measurements to ensure exact measurement. Switching block as shown in Figure 8.

3.2. Designing software

The authors write a software program in C language for the central controller as shown in Figure 9. Using Arduino Nano microcontroller to program through Arduino IDE software.

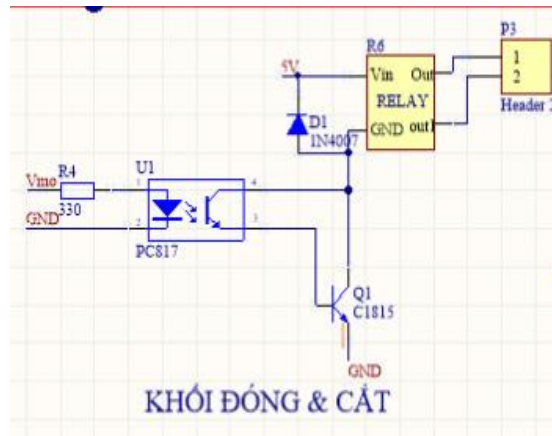

Figure 8. Switching block

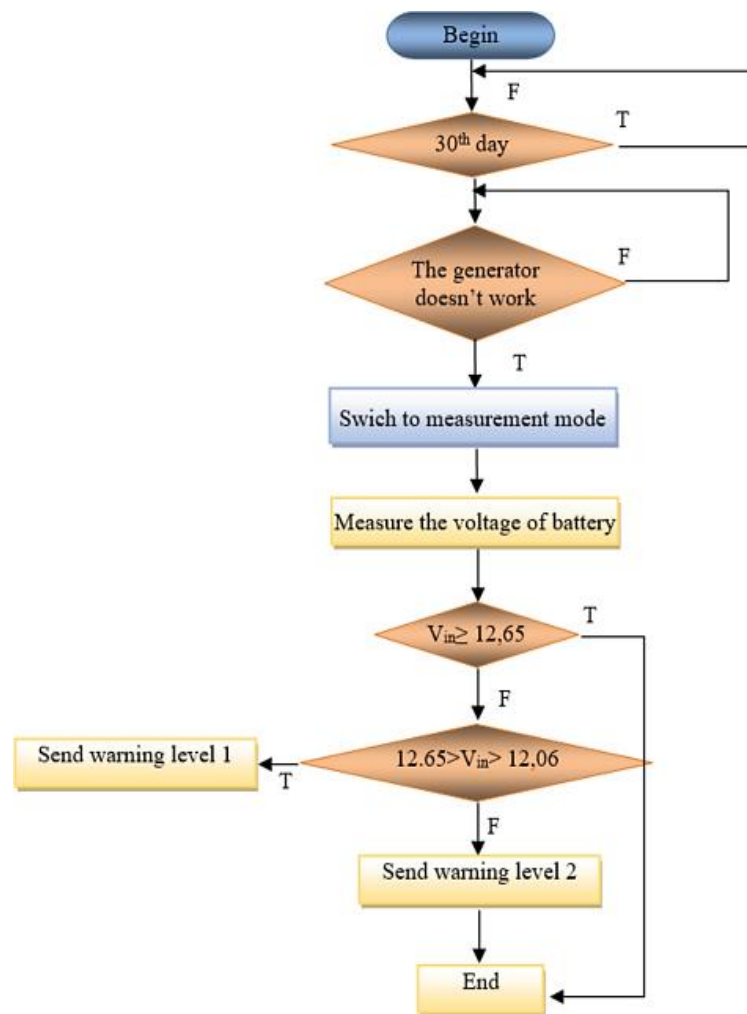

Figure 9. Algorithm flowchart of battery's voltage warning and measurement circuit

4. EXPERIMENT AND RESULTS

Figure 10 shows a general principal diagram of a generator battery operation monitor in a BTS station. In addition to the main components designed in part 3 of the article, the circuit also has an independent power supply circuit using a 5V lithium battery. To design printed circuit boards, we used

Altium designer software. Figure 11(a) is a 2D diagram and Figure 11(b) is a 3D diagram of the board. Figure 12 is a circuit image of the generator battery operation monitor in a BTS station after completion. Figure 13 shows a test image of the product's features by design goal.

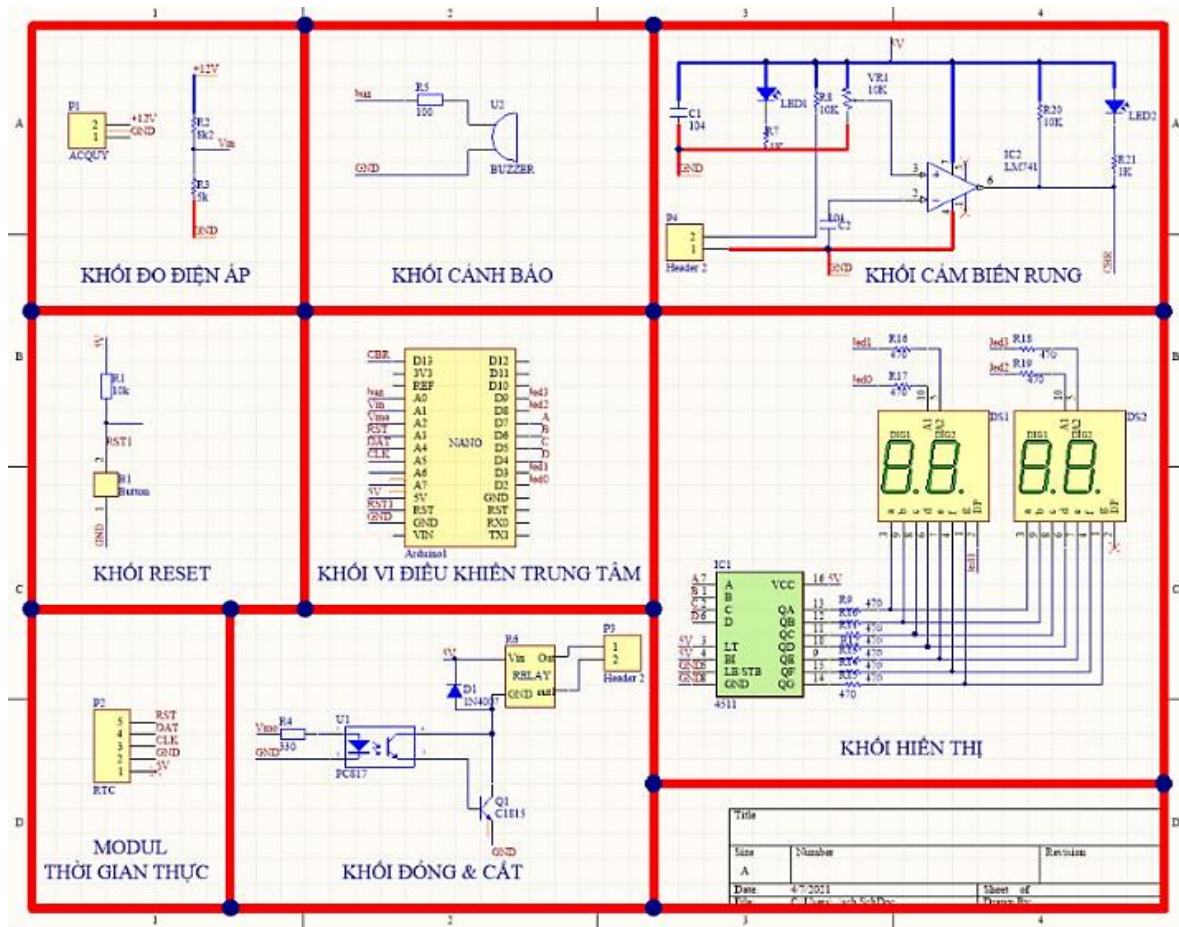

Figure 10. General principal diagram of the equipment

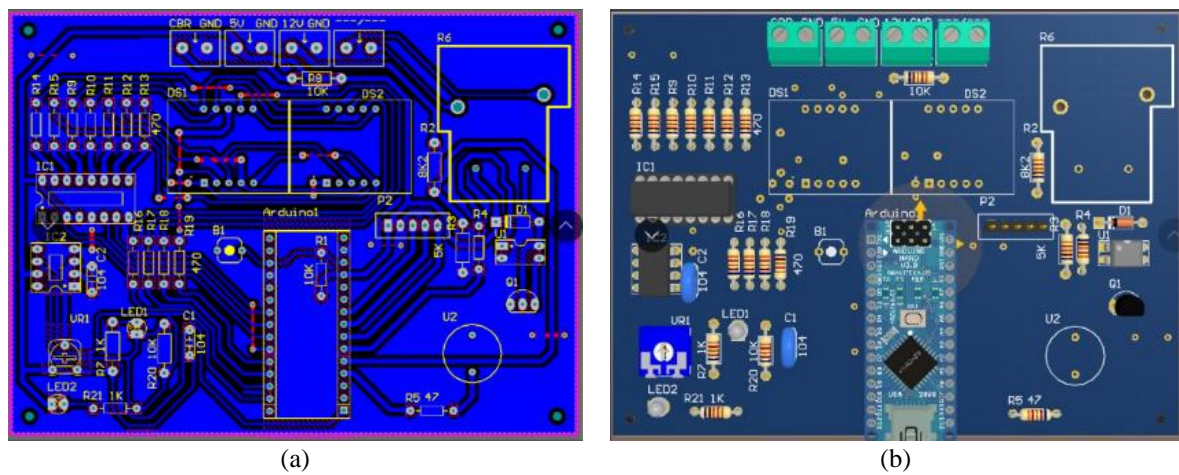

Figure 11. Design printed circuit boards of (a) 2D PCB diagram and (b) 3D PCB diagram



Figure 12. A circuit of the generator battery operation monitor in a BTS station after completion

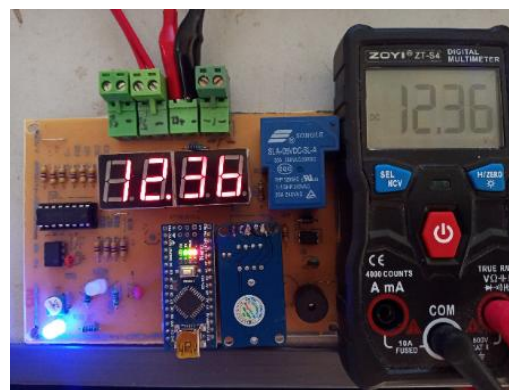

Figure 13. Test the product

5. CONCLUSION

The solution to design the generator battery operation monitor in a BTS station is really a simple, effective, affordable, and easy-to-integrate solution. In this article, the authors surveyed the power supply system for BTS stations, learned about methods to determine the condition of the batteries, proposed solutions, built a test system in the laboratory of Electronic Engineering major, Faculty of Electronic Engineering, Thai Nguyen University of Technology. Experimental results have shown that the system operation is reliable, and meets the requirements of the problem.

ACKNOWLEDGEMENTS

The authors thank the Thai Nguyen University of Technology for funding for the team to design and complete the product.

REFERENCES

- [1] R. Kaur, V. Krishnasamy, K. Muthusamy, and P. Chinnamuthan, "A novel proton exchange membrane fuel cell based power conversion system for telecom supply with genetic algorithm assisted intelligent interfacing converter," *Energy Conversion and Management*, vol. 136, pp. 173–183, Mar. 2017, doi: 10.1016/j.enconman.2017.01.014.
- [2] M. F. Serincan, "Reliability considerations of a fuel cell backup power system for telecom applications," *Journal of Power Sources*, vol. 309, pp. 66–75, Mar. 2016, doi: 10.1016/j.jpowsour.2016.01.083.
- [3] W. W. Wibowo, Y. D. R. W. Astuti, and C. H., "Solar-powered base transceiver station," in *2018 2nd International Conference on Green Energy and Applications (ICGEA)*, Mar. 2018, pp. 108–112, doi: 10.1109/ICGEA.2018.8356275.
- [4] S. Moury, M. Nazim Khandoker, and S. M. Haider, "Feasibility study of solar PV arrays in grid connected cellular BTS sites," in *2012 International Conference on Advances in Power Conversion and Energy Technologies (APCET)*, Aug. 2012, pp. 1–5, doi: 10.1109/APCET.2012.6302053.
- [5] K. Kusakana and H. J. Vermaak, "Hybrid renewable power systems for mobile telephony base stations in developing countries," *Renewable Energy*, vol. 51, pp. 419–425, Mar. 2013, doi: 10.1016/j.renene.2012.09.045.
- [6] SHARETRAILS.ORG, "BatteryStuff.com logo," *BatteryStuff.com LLC. All Rights Reserved*, 2022. <https://www.batterystuff.com/blog/how-to-tell-if-your-battery-is-bad.html>.
- [7] M. Mooney, B. Dobia, and K. Barker, "Positive behaviour for learning: investigating the transfer of a United States system into the NSW Department of Education and Training Western Sydney Region schools," *An electronic journal for leaders in education*, vol. 6, no. 20, pp. 11–19, 2008.
- [8] CADEX, "BU-903: How to measure state-of-charge," *Battery*, 2021. https://batteryuniversity.com/learn/article/how_to_measure_state_of_charge (accessed Nov. 02, 2021).
- [9] A. Nano, "Increase UAV range and runtime with power modules," *Components101*, 2021. <https://components101.com/microcontrollers/arduino-nano> (accessed Jul. 17, 2021).
- [10] Manufacturer, "DS1302 chip datasheet PDF," *Newest Products*, 2020. <https://www.mouser.co.id/new/manufacturers/> (accessed Dec. 09, 2020).